

# 200GBASE-SR4 QSFP56 Optical Transceiver

## Product Features

- Compliant with IEEE 802.3cd-2018 and Annex 120E 200GAUI-4 C2M
- Compliant with CMIS 4.0
- 4x26.5625GBd PAM4 transmitter and PAM4 receiver
- 4 channels 850nm VCSEL array
- 4 channels PIN photo detector array
- 4 channels monitor photo detector array
- Single +3.3V power supply, Power consumption < 5W
- Operation case temperature of 0~70°C
- Standard Optical fiber with MPO-12 UPC optical connector
- Maximum link length of 70m on OM3 MMF and 100m on OM4 MMF with FEC
- RoHS10 compliance, and Class 1 laser safety
- Application: 200G Ethernet

## Absolute Maximum Ratings

Parameter	Unit	Min.	Typical	Max.	Notes
Storage Temperature	°C	-40		85	
Operating Relative Humidity	%	0		85	
Power Supply Voltage	V	-0.5		3.63	

## Recommended Operating Conditions

Parameter	Unit	Min.	Typical	Max.	Notes
Operating Case Temperature	°C	0		70	note1
Power Supply Voltage	V	3.135	3.3	3.465	
Power Supply Current	A			1.6	
Power Consumption	W			5	
Sustained peak Current				2310	
Instantaneous peak current				2800	
Bit Rate	Gbps		212.5		

Note1, Case Temperature here is depending on module case around TOSA, please do remember it is NOT the environmental temperature.

**Electrical Characteristics**

Parameter	Unit	Min.	Typical	Max.	Note
<b>Transmitter</b>					
Signaling rate per lane (range)		26.5625 ± 100 ppm			TP1
Differential pk-pk input voltage tolerance (min)	mV	900	-	-	TP1a
Date Differential Impedance	Ω	90	100	110	
<b>Receiver</b>					
Signaling rate per lane (range)		26.5625 ± 100 ppm			TP4
Differential peak-to-peak output voltage (max)	mV	-	-	900	TP4
Date Differential Impedance	Ω	90	100	110	

**Optical Characteristics**

All performance is specified at whole working temperature and conditions

Parameter	Unit	Min.	Typical	Max.	Note
<b>Transmitter</b>					
Signaling rate, each lane	GBd	26.5625 ± 100 ppm			
Modulation Format		PAM4			
TX Central Wavelength	nm	840	850	860	
Spectral Width (RMS)	nm			0.6	
Average Launch Power, each lane	dBm	-6.5		4	
Outer Optical Modulation Amplitude (OMA <sub>outer</sub> ), each lane	dBm	-4.5		3	
Transmitter and dispersion eye closure for PAM4 (TDECQ), each lane	dB			4.5	
Average Launch power of OFF transmitter, each lane	dBm			-30	
Extinction Ratio, each lane	dB	3			
Optical Return Loss Tolerance	dB			12	1
RIN <sub>12OMA</sub> (max)	dB/Hz			-128	
Encircled Flux		>86% at 19 um <30% at 4.5 um			
<b>Receiver</b>					
Signaling rate, each lane	GBd	26.5625 ± 100 ppm			
Modulation Format		PAM4			
RX Central Wavelength	nm	840	850	860	
Damage threshold (min)	dBm	5			
Average Receive Power, each lane	dBm	-8.4		4	
Receive Power (OMA <sub>outer</sub> ), each lane	dBm			3	
Receiver Reflectance	dB			-12	
Stressed Receiver Sensitivity (OMA <sub>outer</sub> ), each lane	dBm			-3.4	2
Conditions of stressed receiver sensitivity test:					
Stressed eye closure for PAM4 (SECQ), lane under test	dB			4.5	
OMA <sub>outer</sub> of each aggressor lane	dBm			3	
LOS Assert	dBm	-30			
LOS De-Assert	dBm			-12	
LOS Hysteresis	dB	0.5			

**Note:**

1. Coupled into 50/125 MMF.
2. BER=2.4E-4; PRBS31Q@26.5625GBd. Pre-FEC

**Optical Interface**

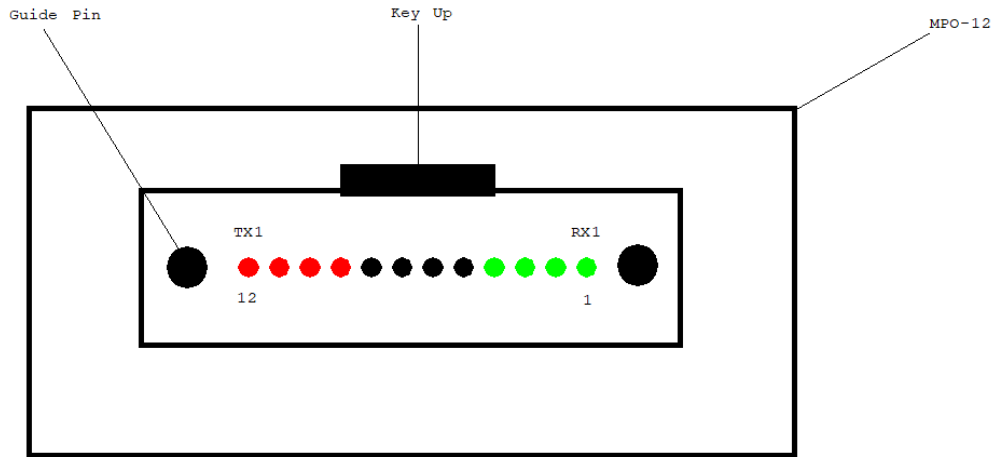

**Figure 1: MPO-12 Single Row optical patch cord and module receptacle**

**Pin Assignment and Description**

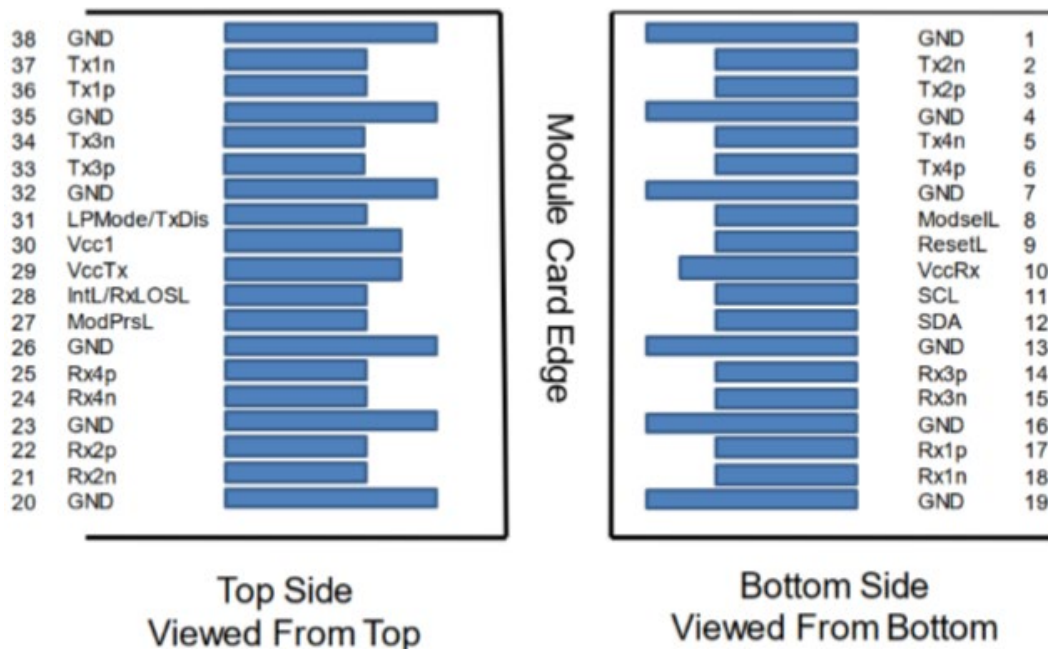

**Figure 2: Module contact definition**

**PIN Definition**

Pad	Logic	Symbol	Description	Plug Sequence	Notes
1		GND	Ground	1	1
2	CML-I	Tx2n	Transmitter Inverted Data Input	3	
3	CML-I	Tx2p	Transmitter Non-Inverted Data Input	3	
4		GND	Ground	1	1
5	CML-I	Tx4n	Transmitter Inverted Data Input	3	
6	CML-I	Tx4p	Transmitter Non-Inverted Data Input	3	
7		GND	Ground	1	1
8	LVTTTL-I	ModSelL	Module Select	3	
9	LVTTTL-I	ResetL	Module Reset	3	
10		VccRx	+3.3V Power Supply Receiver	2	2
11	LVCNOS-I/O	SCL	2-wire serial interface clock	3	
12	LVCNOS-I/O	SDA	2-wire serial interface data	3	
13		GND	Ground	1	1
14	CML-O	Rx3p	Receiver Non-Inverted Data Output	3	
15	CML-O	Rx3n	Receiver Inverted Data Output	3	
16		GND	Ground	1	1
17	CML-O	Rx1p	Receiver Non-Inverted Data Output	3	
18	CML-O	Rx1n	Receiver Inverted Data Output	3	
19		GND	Ground	1	1
20		GND	Ground	1	1
21	CML-O	Rx2n	Receiver Inverted Data Output	3	
22	CML-O	Rx2p	Receiver Non-Inverted Data Output	3	
23		GND	Ground	1	1
24	CML-O	Rx4n	Receiver Inverted Data Output	3	
25	CML-O	Rx4p	Receiver Non-Inverted Data Output	3	
26		GND	Ground	1	1
27	LVTTTL-O	ModPrsL	Module Present	3	
28	LVTTTL-O	IntL/RxL OSL	Interrupt. Optionally configurable as RxLOSL via the management interface(SFF-8636)	3	4
29		VccTx	+3.3V Power supply transmitter	2	2
30		Vcc1	+3.3V Power supply	2	2
31	LVTTTL-I	LPMODE/ TxDis	Low Power Mode. Optionally configurable as TxDis via the management interface(SFF-8636)	3	3
32		GND	Ground	1	1
33	CML-I	Tx3p	Transmitter Non-Inverted Data Input	3	

34	CML-I	Tx3n	Transmitter Inverted Data Input	3	
35		GND	Ground	1	1
36	CML-I	Tx1p	Transmitter Non-Inverted Data Input	3	
37	CML-I	Tx1n	Transmitter Inverted Data Input	3	
38		GND	Ground	1	1

Note 1: GND is the symbol for signal and supply (power) common for the module. All are common within the module and all module voltages are referenced to this potential unless otherwise noted. Connect these directly to the host board signal-common ground plane.

Note 2: VccRx, Vcc1 and VccTx shall be applied concurrently and be internally connected within the module in any combination.

Vcc contacts in SFF-8662 and SFF-8672 each have a steady state current rating of 1A.

Note 3: Pin31 TxDis(fast mode) is available.

Note 4: Pin 28 RxLOS(fast mode) is available.

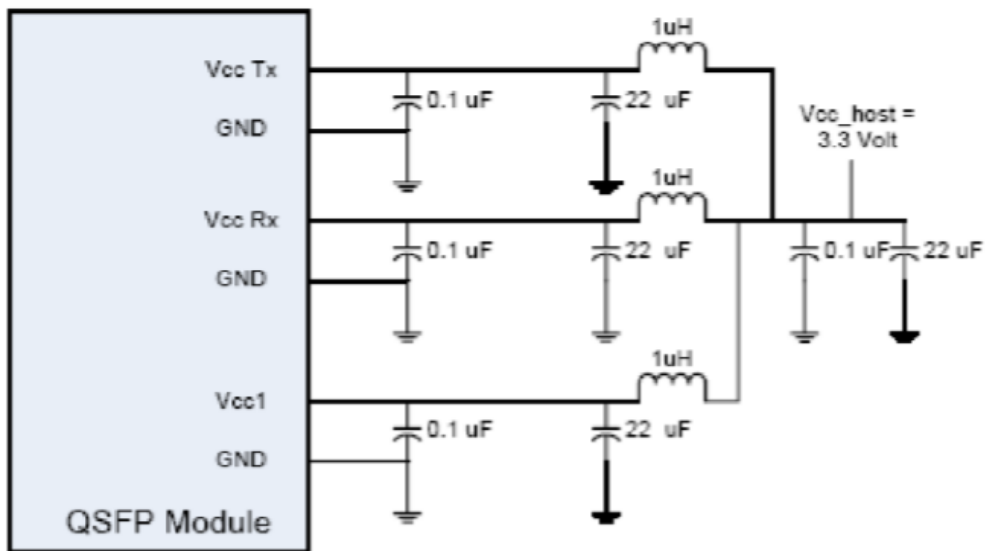

**Figure 3: Recommended Host Board Power Supply Filtering**

OUTLINES

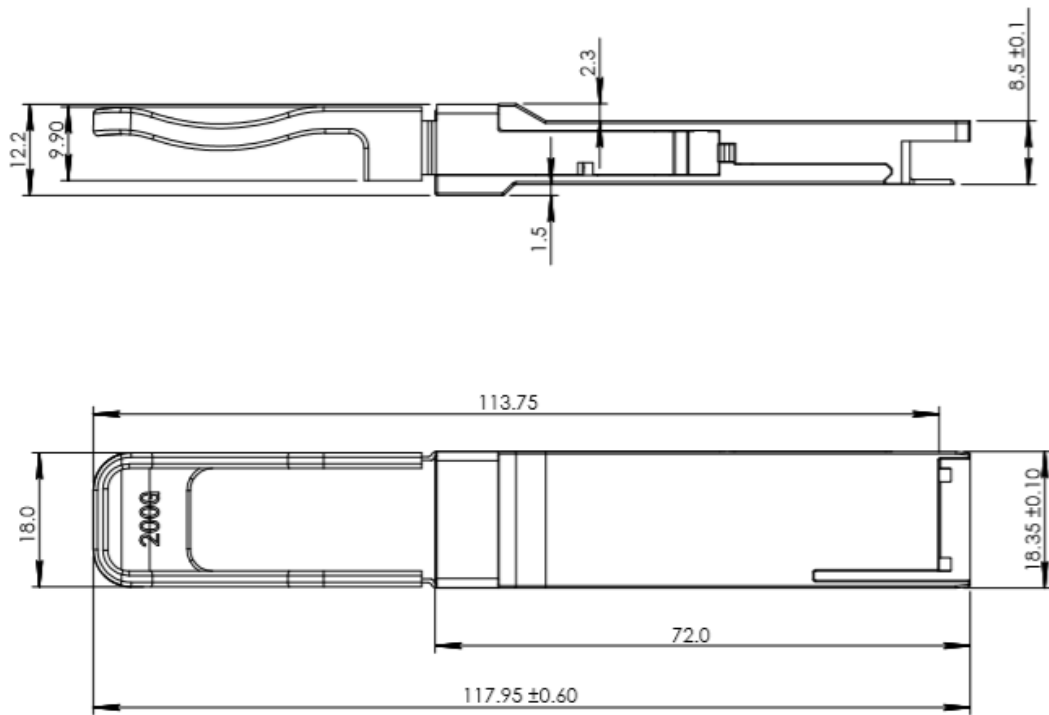

Figure 4. Mechanical Outline

**Digital Diagnostic Functions**

Parameter	Units	Error	NOTES
Temperature Monitor	°C	±3	1LSB=1/256°C
Supply Voltage Monitor	V	±0.1	1LSB=100uV
Bias Current Monitor	mA	±10%	1LSB=2uA
TX Power Monitor	dB	±3	1LSB=0.1uW
RX Power Monitor	dB	±3	1LSB=0.1uW

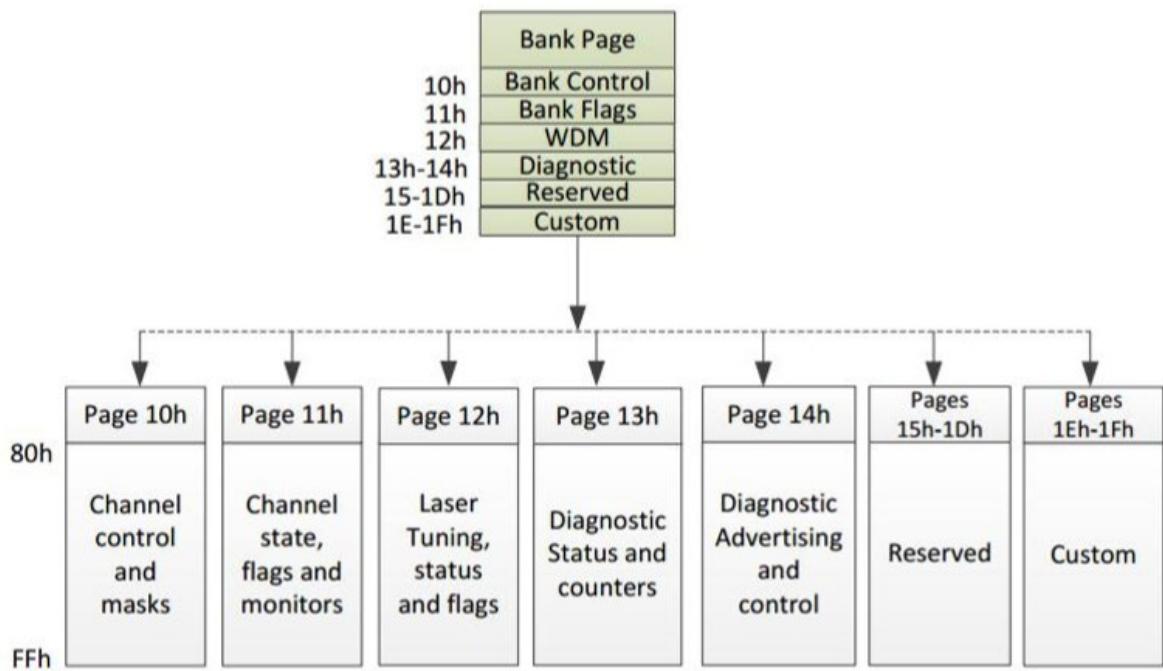

Figure 5. Additional Supported Bank Page Memory Map



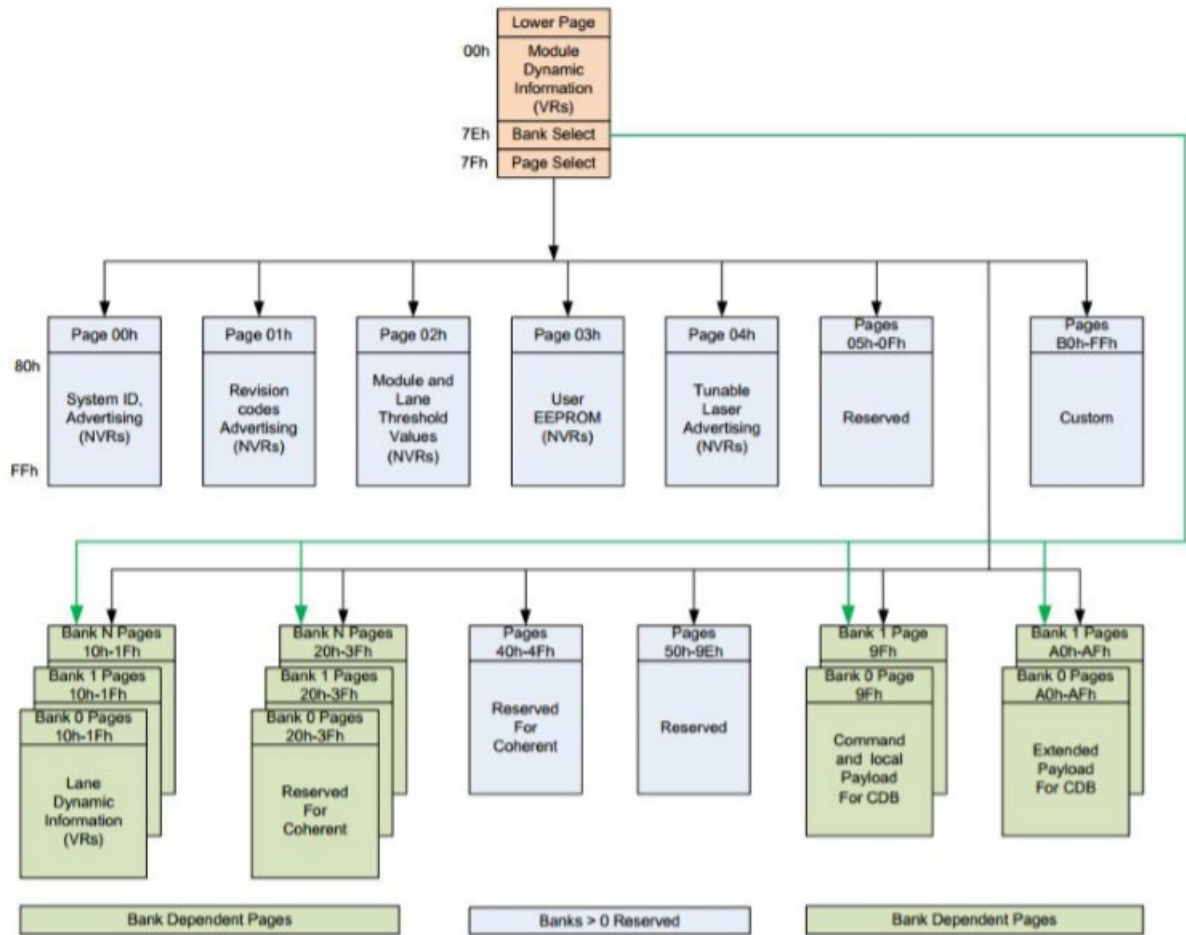

Figure 6. CMIS Bank Page Memory Map

**ESD**

This transceiver is specified as ESD threshold 1kV for high speed data pins and 2kV for all other electrical input pins, tested per MIL-STD-883, Method 3015.4 /JESD22-A114-A (HBM). However, normal ESD precautions are still required during the handling of this module. This transceiver is shipped in ESD protective packaging. It should be removed from the packaging and handled only in an ESD protected environment.

**Laser Safety**

This is a Class 1 Laser Product according to IEC 60825-1:2007. This product complies with 21 CFR 1040.10 and 1040.11 except for deviations pursuant to Laser Notice No. 50, dated (June 24, 2007).

**Ordering Information**

Ordering P/Ns	Description
DH88jj-KMCA	4x50G QSFP56 SR4, 850nm, MMF, MPO, Commercial temperature.

**Contact Us**

 **太平貿易株式会社**  
**TAIHEI BOEKI CO., LTD.**

光学機器課

〒103-0023 東京都中央区日本橋本町2-2-2

TEL 03-3270-4826 FAX 03-3245-1767

<http://www.taiheiboeki.co.jp>

[tokyo@taiheiboeki.co.jp](mailto:tokyo@taiheiboeki.co.jp)

Copyright © 2020 Broadex Technologies. All rights reserved