

200GBASE-FR4 QSFP56 Optical Transceiver

Product Features

- Compliant with IEEE 802.3bs and Annex 120E 200GAUI-4 C2M
- Compliant with CMIS 4.0
- 4x26.5625GBd PAM4 transmitter and PAM4 receiver
- Optical Transmitter: CWDM EA-DFB
- Optical Receiver: PIN photo detector
- 4 channels monitor photo detector
- Single +3.3V power supply, Power consumption < 7W
- Operation case temperature of 0~70°C
- Duplex LC connector
- Maximum link length of 2km on SMF
- RoHS10 compliance, and Class 1 laser safety
- Application: Data center, enterprise, and telecom applications

Absolute Maximum Ratings

Parameter	Unit	Min.	Typical	Max.	Notes
Storage Temperature	°C	-40		85	
Operating Relative Humidity	%	0		85	
Power Supply Voltage	V	-0.5		3.63	

Recommended Operating Conditions

Parameter	Unit	Min.	Typical	Max.	Notes
Operating Case Temperature	°C	0		70	note1
Power Supply Voltage	V	3.135	3.3	3.465	
Power Supply Current	A			2.2	
Power Consumption	W			7	
Bit Rate	Gbps		212.5		

Note1, Case Temperature here is depending on module case around TOSA, please do remember it is NOT the environmental temperature.

Electrical Characteristics

Parameter	Unit	Min.	Typical	Max.	Note
Transmitter					

Signaling rate per lane (range)		26.5625 ± 100 ppm			TP1
Differential pk-pk input voltage tolerance (min)	mV	900	-	-	TP1a
Date Differential Impedance	Ω	90	100	110	
Receiver					
Signaling rate per lane (range)		26.5625 ± 100 ppm			TP4
Differential peak-to-peak output voltage (max)	mV	-	-	900	TP4
Date Differential Impedance	Ω	90	100	110	

Optical Characteristics

All performance is specified at whole working temperature and conditions

Parameter	Unit	Min.	Typical	Max.	Note
Transmitter					
Signaling rate, each lane	GBd	26.5625 ± 100 ppm			
Modulation Format		PAM4			
Lane wavelengths (range)	nm	1264.5	1271	1277.5	
	nm	1284.5	1291	1297.5	
	nm	1304.5	1311	1317.5	
	nm	1324.5	1331	1337.5	
Side-mode suppression ratio (SMSR), (min)	dB	30			
Total average launch power (max)	dBm	10.7			
Average Launch Power, each lane	dBm	-4.2		4.7	
Outer Optical Modulation Amplitude (OMA _{outer}), each lane	dBm	-1.2		4.5	
Difference in launch power between any two lanes (OMA _{outer}) (max)	dB			4	
Launch power in OMA _{outer} minus TDECQ, each lane (min):	dBm	-2.6			
	dBm	-2.5			
for extinction ratio ≥ 4.5 dB					
for extinction ratio < 4.5 dB					
Transmitter and dispersion eye closure for PAM4 (TDECQ), each lane	dB			3.3	
Average Launch power of OFF transmitter, each lane	dBm			-30	
Extinction Ratio, each lane	dB	3.5			
Optical Return Loss Tolerance	dB			16.5	
RIN _{16.5OMA} (max)	dB/Hz			-132	
Transmitter reflectance (max)	dB			-26	
Receiver					
Signaling rate, each lane	GBd	26.5625 ± 100 ppm			

Modulation Format		PAM4			
Lane wavelengths (range)	nm	1264.5	1271	1277.5	
	nm	1284.5	1291	1297.5	
	nm	1304.5	1311	1317.5	
	nm	1324.5	1331	1337.5	
Damage threshold (min)	dBm	5.7			
Average Receive Power, each lane	dBm	-8.2		4.7	
Receive Power (OMAouter), each lane	dBm			4.5	
Difference in receive power between any two lanes (OMAouter) (max)	dB			4.1	
Receiver Reflectance	dB			-26	
Stressed Receiver Sensitivity (OMAouter), each lane	dBm			-3.6	1
Receiver sensitivity (OMAouter), each lane (max)	dBm			-6	
Conditions of stressed receiver sensitivity test:					
Stressed eye closure for PAM4 (SECQ), lane under test	dB	3.3			
OMAouter of each aggressor lane	dBm	0.5			
LOS Assert	dBm	-20			
LOS De-Assert	dBm			-10.3	
LOS Hysteresis	dB	0.5			

Note:

1. BER=2.4E-4; PRBS31Q@26.5625GBd. Pre-FEC

Pin Assignment and Description

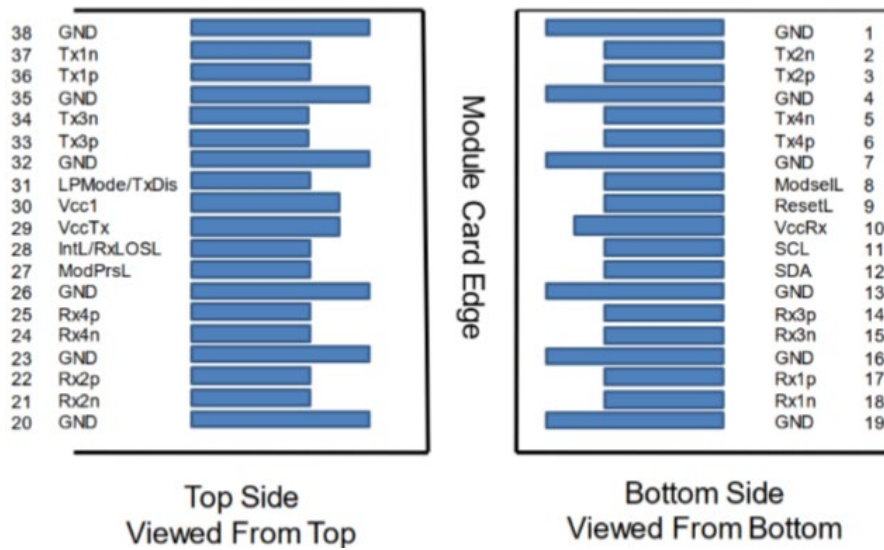

Figure 1: Module contact definition

PIN Definition

Pad	Logic	Symbol	Description	Plug Sequence	Notes
1		GND	Ground	1	1
2	CML-I	Tx2n	Transmitter Inverted Data Input	3	
3	CML-I	Tx2p	Transmitter Non-Inverted Data Input	3	
4		GND	Ground	1	1
5	CML-I	Tx4n	Transmitter Inverted Data Input	3	
6	CML-I	Tx4p	Transmitter Non-Inverted Data Input	3	
7		GND	Ground	1	1
8	LVTTL-I	ModSelL	Module Select	3	
9	LVTTL-I	ResetL	Module Reset	3	
10		VccRx	+3.3V Power Supply Receiver	2	2
11	LVC MOS-I/O	SCL	2-wire serial interface clock	3	
12	LVC MOS-I/O	SDA	2-wire serial interface data	3	
13		GND	Ground	1	1
14	CML-O	Rx3p	Receiver Non-Inverted Data Output	3	
15	CML-O	Rx3n	Receiver Inverted Data Output	3	
16		GND	Ground	1	1
17	CML-O	Rx1p	Receiver Non-Inverted Data Output	3	
18	CML-O	Rx1n	Receiver Inverted Data Output	3	
19		GND	Ground	1	1

20		GND	Ground	1	1
21	CML-O	Rx2n	Receiver Inverted Data Output	3	
22	CML-O	Rx2p	Receiver Non-Inverted Data Output	3	
23		GND	Ground	1	1
24	CML-O	Rx4n	Receiver Inverted Data Output	3	
25	CML-O	Rx4p	Receiver Non-Inverted Data Output	3	
26		GND	Ground	1	1
27	LVTTTL-O	ModPrsL	Module Present	3	
28	LVTTTL-O	IntL/RxL OSL	Interrupt. Optionally configurable as RxLOS via the management interface (SFF-8636)	3	4
29		VccTx	+3.3V Power supply transmitter	2	2
30		Vcc1	+3.3V Power supply	2	2
31	LVTTTL-I	LPMoDe/ TxDis	Low Power Mode. Optionally configurable as TxDis via the management interface (SFF-8636)	3	3
32		GND	Ground	1	1
33	CML-I	Tx3p	Transmitter Non-Inverted Data Input	3	
34	CML-I	Tx3n	Transmitter Inverted Data Input	3	
35		GND	Ground	1	1
36	CML-I	Tx1p	Transmitter Non-Inverted Data Input	3	
37	CML-I	Tx1n	Transmitter Inverted Data Input	3	
38		GND	Ground	1	1

Note 1: GND is the symbol for signal and supply (power) common for the module. All are common within the module and all module voltages are referenced to this potential unless otherwise noted. Connect these directly to the host board signal-common ground plane.

Note 2: VccRx, Vcc1 and VccTx shall be applied concurrently and be internally connected within the module in any combination.

Vcc contacts in SFF-8662 and SFF-8672 each have a steady state current rating of 1A.

Note 3: Pin31 TxDis (fast mode) is available.

Note 4: Pin 28 RxLOS (fast mode) is available.

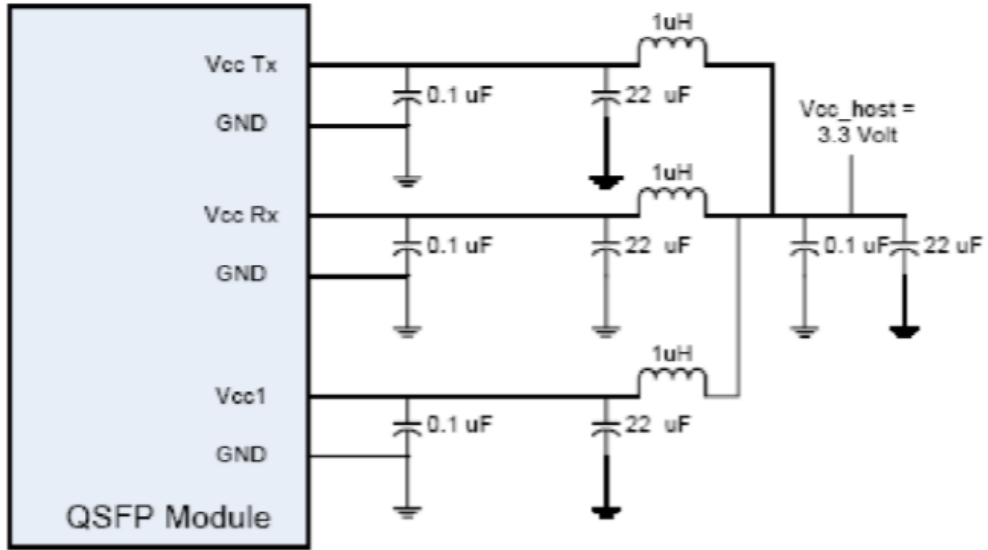

Figure 2: Recommended Host Board Power Supply Filtering

OUTLINES

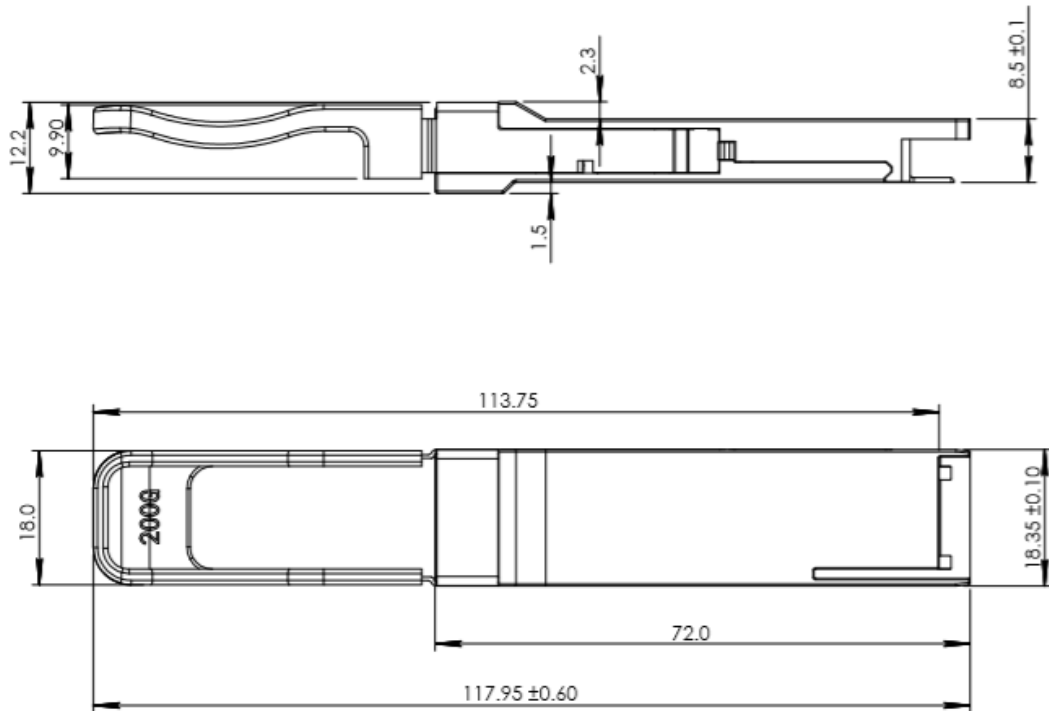

Figure 3. Mechanical Outline

Digital Diagnostic Functions

Parameter	Units	Error	NOTES
Temperature Monitor	°C	±3	1LSB=1/256°C
Supply Voltage Monitor	V	±0.1	1LSB=100uV
Bias Current Monitor	mA	±10%	1LSB=2uA
TX Power Monitor	dB	±3	1LSB=0.1uW
RX Power Monitor	dB	±3	1LSB=0.1uW

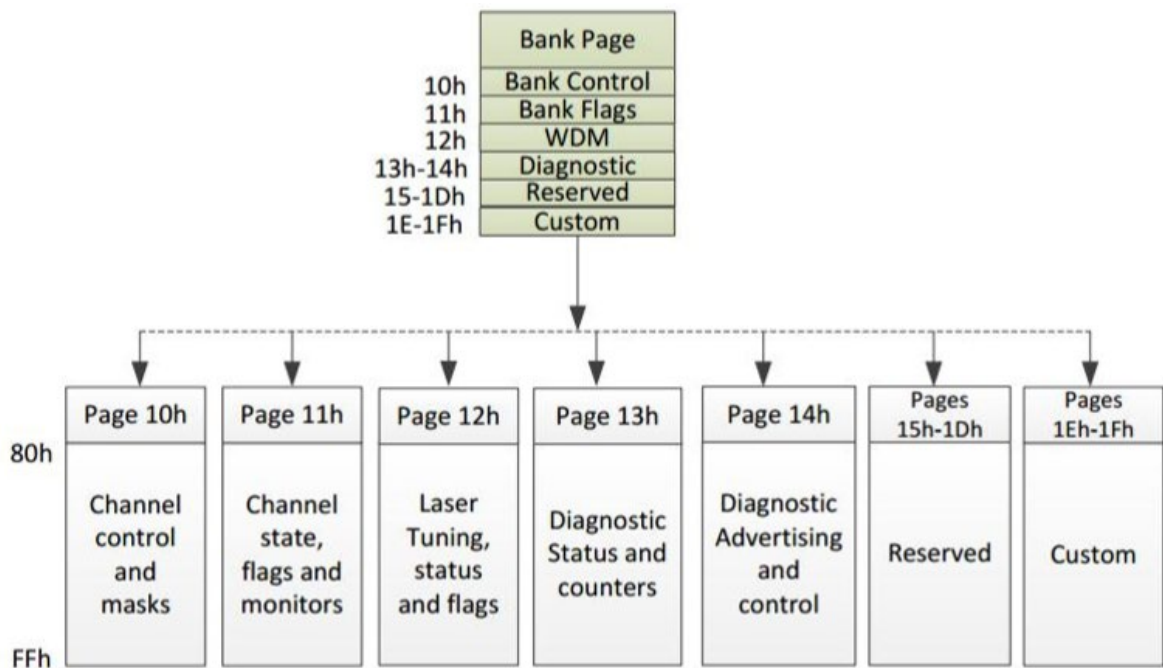

Figure 5. Additional Supported Bank Page Memory Map

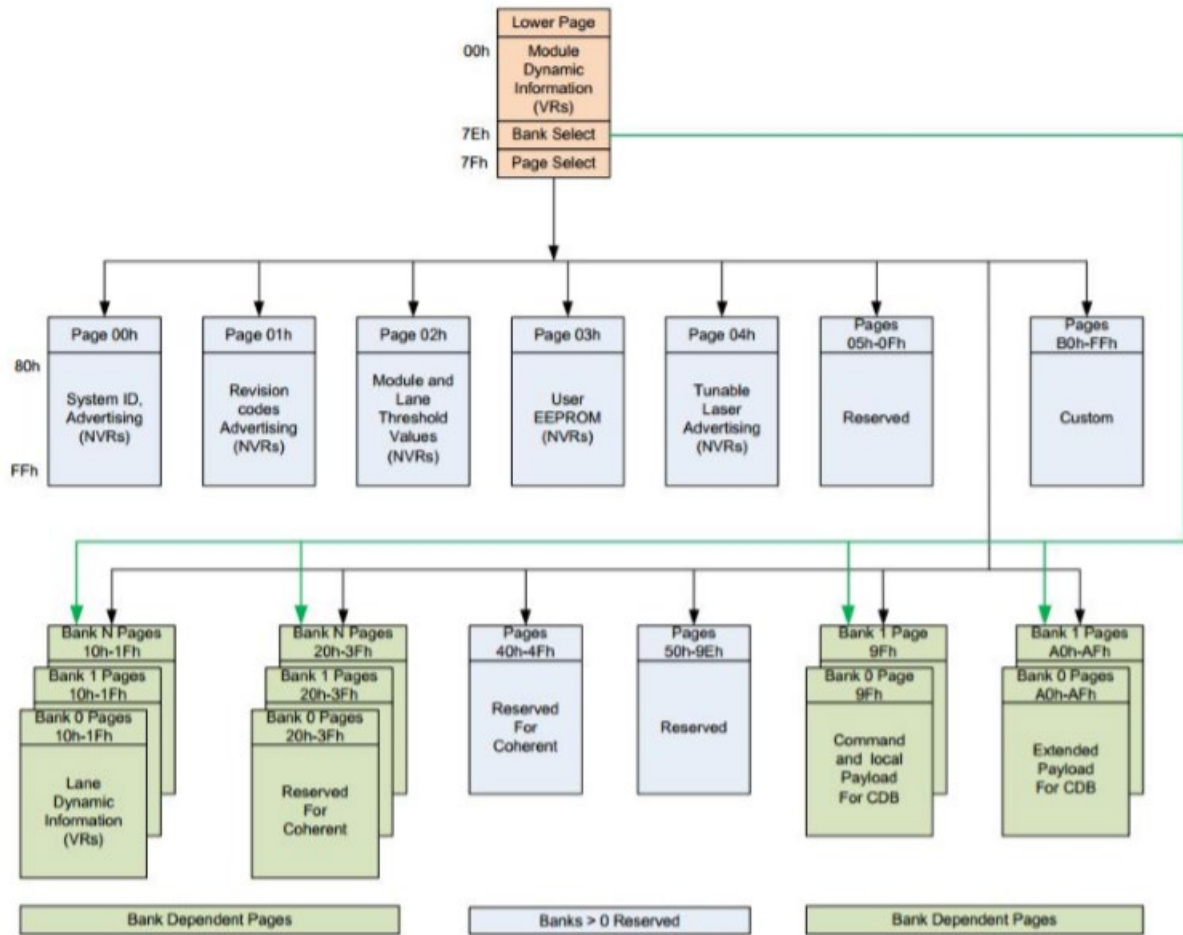

Figure 6. CMIS Bank Page Memory Map

ESD

This transceiver is specified as ESD threshold 1kV for high speed data pins and 2kV for all other electrical input pins, tested per MIL-STD-883, Method 3015.4 /JESD22-A114-A (HBM). However, normal ESD precautions are still required during the handling of this module. This transceiver is shipped in ESD protective packaging. It should be removed from the packaging and handled only in an ESD protected environment.

Laser Safety

This is a Class 1 Laser Product according to IEC 60825-1:2007. This product complies with 21 CFR 1040.10 and 1040.11 except for deviations pursuant to Laser Notice No. 50, dated (June 24, 2007).

Ordering Information

Ordering P/Ns	Description
DDCCjj-KLCA	2km, 4x50G QSFP56 FR4, CWDM4 1271/1291/1311/1331nm, LC/UPC optical interface, commercial temperature

Contact Us

 太平貿易株式会社

TAIHEI BOEKI CO., LTD.

光学機器課

〒103-0023 東京都中央区日本橋本町2-2-2

TEL 03-3270-4826 FAX 03-3245-1767

<http://www.taiheiboeki.co.jp>

tokyo@taiheiboeki.co.jp

Copyright © 2020 Broadex Technologies. All rights reserved