

100G QSFP28 CWDM4 Optical Transceiver

Product Features

- Compliant to the QSFP28 MSA SFF-8636
- Uncooled CWDM DFB directly modulated lasers and PIN array receiver
- Transmission data rate up to 25.78125Gbps per channel
- Electrical interface: retimed CAUI-4 as defined in 100G Ethernet IEEE 802.3bm Annex 83E
- 2m~2km link length over G.652 fiber
- Fiber Connector: SMF LC duplex connector
- Single +3.3V power supply
- Maximum operation power: 3.5W
- Operation case temperature: 0 to 70°C
- RoHS6 compliant

Applications

- Data Center Interconnect
- Enterprise and Telecom Networking

Absolute Maximum Ratings

Parameter	Unit	Min.	Typical	Max.	Notes
Storage Temperature	°C	-40		85	
Operating Relative Humidity	%	0		85	
Power Supply Voltage	V	-0.5		3.63	

Recommended Operating Conditions

Parameter	Unit	Min.	Typical	Max.	Notes
Operating Case Temperature	°C	0		70	
Power Supply Working Voltage	V	3.135	3.3	3.465	
Power Consumption	W			3.5	
Bit Rate	Gbps	10.3125	25.78125		

Optical Characteristics

All performance is defined over the Recommended Operating Environment unless otherwise specified.

Parameter	Unit	Min.	Typical	Max.	Notes
Transmitter (4X25G)					
TX Central Wavelength	nm	1264.5	1271	1277.5	
		1284.5	1291	1297.6	
		1304.5	1311	1317.5	
		1324.5	1331	1337.5	
Signaling rate, each lane	Gb/s		25.78125		
SMSR	dB	30			
Data Input Swing Differential/TX	mV	300	-	1100	
Data Differential Impedance	Ω	90	100	110	
Average Launch power Tx_off	dBm	-	-	-30	
Total Average Launch Optical Power	dBm			8.5	
Average Pav Each Lane	dBm	-6.5		2.5	
Extinction Ratio	dB	3.5	-	-	
OMA per Lane	dBm	-4.0		2.5	
Launch Power in OMA Minus TDP, each lane	dBm	-5.0			
Transmitter & Dispersion Penalty, each lane	dB			3.0	
Transmitter Optical Mask	dB	{0.31, 0.4, 0.45, 0.34, 0.38, 0.4}			
Relative Intensity Noise	dB/Hz			-130	
Transmitter Reflectance	dB			-12	
Optical Return Loss Tolerance	dB			20	
Receiver (4X25G)					
RX Central Wavelength	nm	1264.5	1271	1277.5	
		1284.5	1291	1297.6	
		1304.5	1311	1317.5	
		1324.5	1331	1337.5	
Data Output Swing Differential/RX	mV	500		800	
Data Differential Impedance	Ω	90	100	110	
Average Receive Power, each lane	dBm			2.5	
Sensitivity(OMA)@BER=5E-5, PRBS31	dBm	-	-	-10	
Stressed Receiver Sensitivity (OMA) per Channel @BER=5E-5, PRBS31	dBm	-	-	-7.3	
Difference in Receive Power between any two lanes (OMA)	dB			5.5	
Receiver Saturation, OMA	dBm	3.5	-	-	
Receiver Reflectance	dB			-26	
LOS Assert	dBm	-30	-	-	
LOS De-Assert	dBm	-	-	-12	
LOS Hysteresis	dB	0.5	-	-	

PIN Function Definitions

Pin No.	Symbol	Level / Logic	Description	Notes
1	GND		Module Ground	1
2	Tx2n	CML-I	Transmitter Inverted Data Input	
3	Tx2p	CML-I	Transmitter Non-Inverted Data Input	
4	GND		Module Ground	1
5	Tx4n	CML-I	Transmitter Inverted Data Input	
6	Tx4p	CML-I	Transmitter Non-Inverted Data Input	
7	GND		Module Ground	1
8	ModSelL	LVTTL-I	Module Select	
9	ResetL	LVTTL-I	Module Reset	
10	VccRx		+3.3V Power Supply for Receiver	2
11	SCL	LVTTL-I	2-Wire Serial Interface Clock	
12	SDA	LVTTL-I/O	2-Wire Serial Interface Data Line	
13	GND		Module Ground	1
14	Rx3p	CML-O	Receiver Non-Inverted Data Output	
15	Rx3n	CML-O	Receiver Inverted Data Output	
16	GND		Module Ground	1
17	Rx1p	CML-O	Receiver Non-Inverted Data Output	
18	Rx1n	CML-O	Receiver Inverted Data Output	
19	GND		Module Ground	1
20	GND		Module Ground	1
21	Rx2n	CML-O	Receiver Inverted Data Output	
22	Rx2p	CML-O	Receiver Non-Inverted Data Output	
23	GND		Module Ground	1
24	Rx4n	CML-O	Receiver Inverted Data Output	
25	Rx4p	CML-O	Receiver Non-Inverted Data Output	
26	GND		Module Ground	1
27	ModPrsL	LVTTL-O	Module Present	
28	IntL	LVTTL-O	Interrupt	
29	VccTx		+3.3V Power Supply for Transmitter	2
30	Vcc1		+3.3V Power Supply	2
31	LPMODE	LVTTL-I	Low Power Mode	
32	GND		Module Ground	1
33	Tx3p	CML-I	Transmitter Non-Inverted Data Input	
34	Tx3n	CML-I	Transmitter Inverted Data Input	
35	GND		Module Ground	1
36	Tx1p	CML-I	Transmitter Non-Inverted Data Input	
37	Tx1n	CML-I	Transmitter Inverted Data Input	
38	GND		Module Ground	1

Notes:

- 1: GND is the symbol for signal and supply (power) common for the QSFP28 module. All are common within the QSFP28 module and all module voltages are referenced to this potential unless otherwise noted. Connect these directly to the host board signal-common ground plane.
- 2: Vcc Rx, Vcc1 and Vcc Tx are the receiver and transmitter power supplies and shall be applied concurrently. Vcc Rx, Vcc1 and Vcc Tx may be internally connected within the QSFP28 Module in any combination. The connector pins are each rated for a maximum current of 500mA.

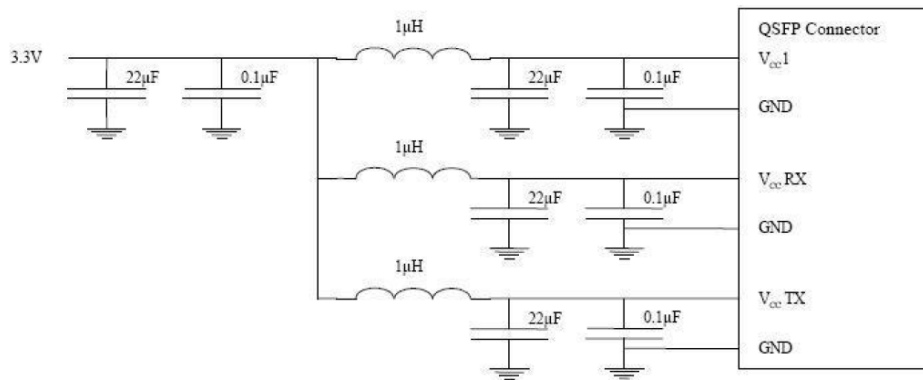

Function block diagram

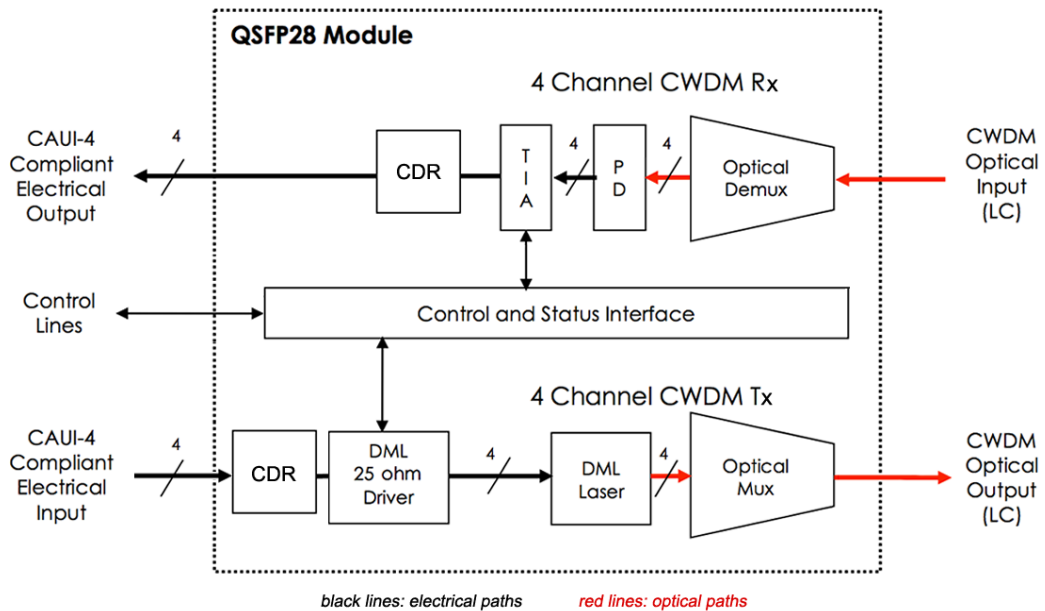

Electrical Pad Layout

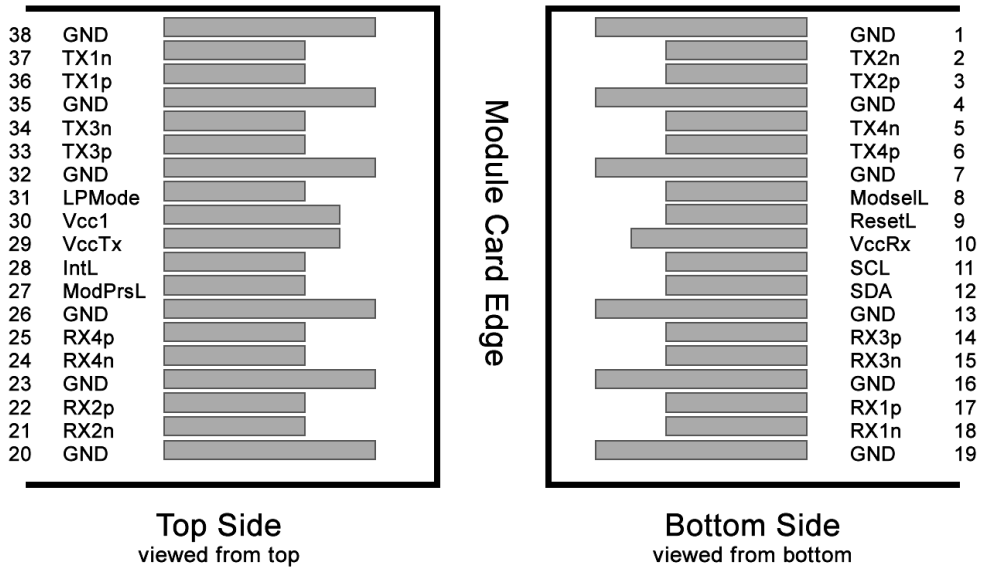

Mechanical Specifications

The mechanical dimensions of this QSFP28 module meets the package outline defined in QSFP+ SFF-8661 Rev 2.3 specification.

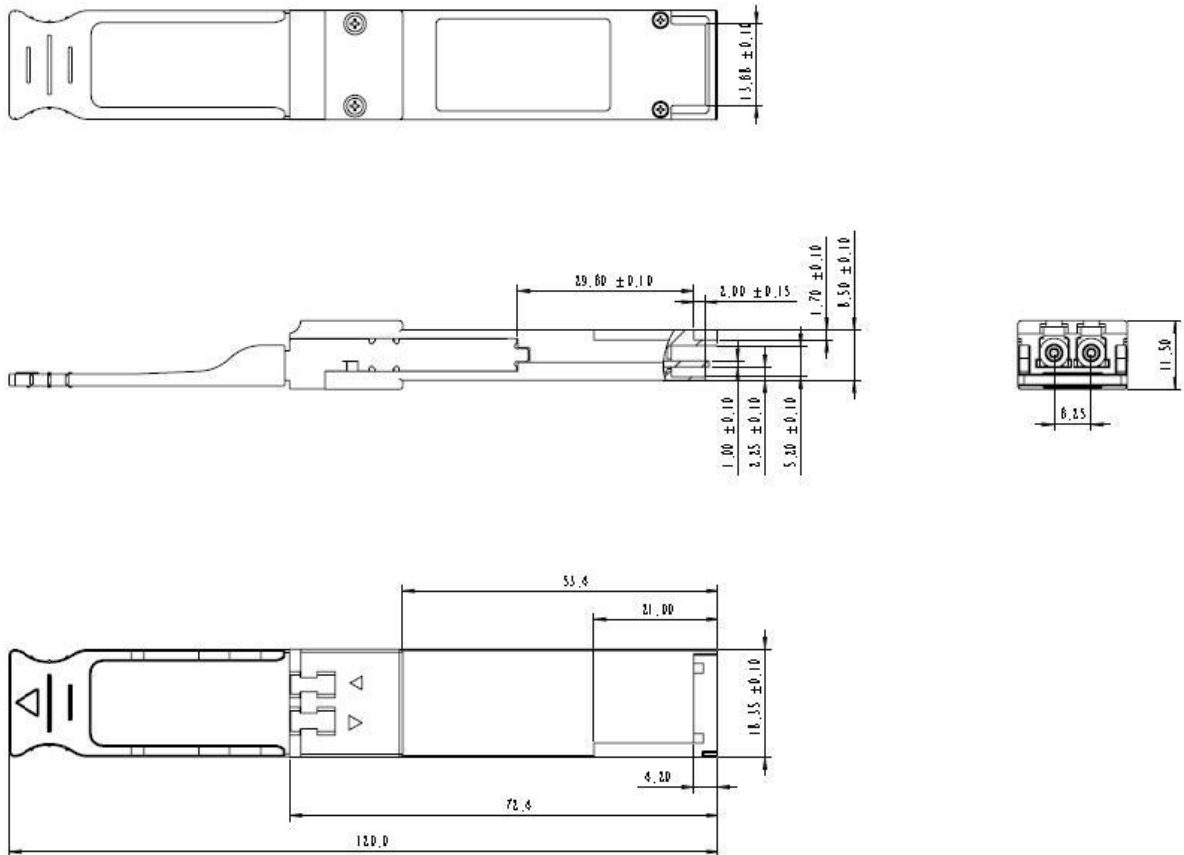

ESD

This transceiver is specified as ESD threshold 1kV for high speed data pins and 2kV for all other electrical input pins, tested per MIL-STD-883, Method 3015.4 /JESD22-A114-A (HBM). However, normal ESD precautions are still required during the handling of this module. This transceiver is shipped in ESD protective packaging. It should be removed from the packaging and handled only in an ESD protected environment.

Laser Safety

This is a Class 1 Laser Product according to IEC 60825-1:2007. This product complies with 21 CFR 1040.10 and 1040.11 except for deviations pursuant to Laser Notice No. 50, dated (June 24, 2007).

Ordering Information

Ordering P/Ns	Description
DDCChh-QLCA	2km, CWDM 1271/1291/1311/1331nm, 4*25G NRZ electrical interface, 4*25G NRZ at LC/UPC optical interface, QSFP28, commercial temperature

Contact Us



太平貿易株式会社

TAIHEI BOEKI CO., LTD.

光学機器課

〒103-0023 東京都中央区日本橋本町2-2-2

TEL 03-3270-4826 FAX 03-3245-1767

<http://www.taiheiboeki.co.jp>

tokyo@taiheiboeki.co.jp

Copyright © 2020 Broadex Technologies. All rights reserved