

50GBASE-LR QSFP28 BIDI Optical Transceiver

Product Features

- Supports 50GBASE-LR
- Up to 10km over SMF
- 25G DFB Transmitter
- 25G PIN Receiver
- Supports 2x25Gbps Host Interface
- Supports 53.125Gbps optical Interface
- QSFP28 MSA Package with Single LC Connector
- I2C management interface with Digital Diagnostic Monitoring
- Compliant to SFF-8636
- Single 3.3V power supply
- Operating case temperature: 0~70°C
- Maximum power dissipation 3.5W
- RoHS-6 compliance

Application

- 50GBASE-LR Ethernet Links

Absolute Maximum Ratings

Parameter	Unit	Min.	Typical	Max.
Storage Temperature	°C	-40		85
Operating Case Temperature	°C	0		70
Operating Relative Humidity	%	5		85
Power Supply not Damaged Voltage	V	0		3.6

Recommended Operating Conditions

Parameter	Unit	Min.	Typical	Max.
Operating Case Temperature	°C	0		70
Operating Relative Humidity	%	5		85
Power Supply Working Voltage	V	3.135	3.3	3.465
Power Consumption	W			3.5
Link Distance	km			10

Characteristics

All performance is specified at whole working temperature and conditions

Parameter	Unit	Min.	Typical	Max.	Note
Transmitter					
Signaling Rate	GBd	26.5625±100ppm			
Module Format		PAM4			
TX Central Wavelength	nm	1260	1270	1280	
		1320	1330	1340	
Side-Mode Suppression Ratio	dB	30			
Average launch power	dBm	-4.5		4.2	
Launch Power in OMA minus TDECQ	dBm	-2.9			
Outer Optical Modulation Amplitude (OMA _{outer})	dBm	-1.5		4	
TDECQ	dB			3.4	
Average launch power of OFF transmitter	dB			-16	
Extinction ratio	dB	3.5			
RIN ₁₅ OMA	dB/Hz			-132	
Optical return loss tolerance	dB			15.6	
Transmitter reflectance	dB			-26	
Receiver					
Signaling Rate	GBd	26.5625±100ppm			
Module Format		PAM4			
RX Central Wavelength	nm	1320	1330	1340	
		1260	1270	1280	
Damage threshold	dBm	5.2			
Average receive power	dBm	-10.8		4.2	Note1
Receive power OMA	dBm			4	
Receiver reflectance	dB			-26	
Receiver sensitivity OMA	dBm			max{-8.4,SECQ -9.8}	
Stress Sensitivity OMA	dBm			-6.4	

Note1, Average receive power (min) is informative and not the principal indicator of signal strength. A received power below this value cannot be compliant; however, a value above this does not ensure compliance

PIN Function Definitions

Pin No.	Symbol	Description
1	GND	Ground
2	Tx2n	Transmitter Inverted Data Input
3	Tx2p	Transmitter Non-Inverted Data Input
4	GND	Ground
5	NC	
6	NC	
7	GND	Ground
8	ModSelL	Module Select
9	ResetL	Module Reset
10	Vcc Rx	+3.3V Power Supply Receiver
11	SCL	2-wire serial interface clock
12	SDA	2-wire serial interface data
13	GND	Ground
14	NC	
15	NC	
16	GND	Ground
17	Rx1p	Receiver Non-Inverted Data Output
18	Rx1n	Receiver Inverted Data Output
19	GND	Ground
20	GND	Ground
21	Rx2n	Receiver Inverted Data Output
22	Rx2p	Receiver Non-Inverted Data Output
23	GND	Ground
24	NC	
25	NC	
26	GND	Ground
27	ModPrsL	Module Present
28	IntL	Interrupt
29	VccTx	+3.3V Power supply transmitter
30	Vcc1	+3.3V Power supply
31	LPMODE	Low Power Mode
32	GND	Ground
33	NC	
34	NC	
35	GND	Ground
36	Tx1p	Transmitter Non-Inverted Data Input
37	Tx1n	Transmitter Inverted Data Input
38	GND	Ground

Typical Interface Circuit

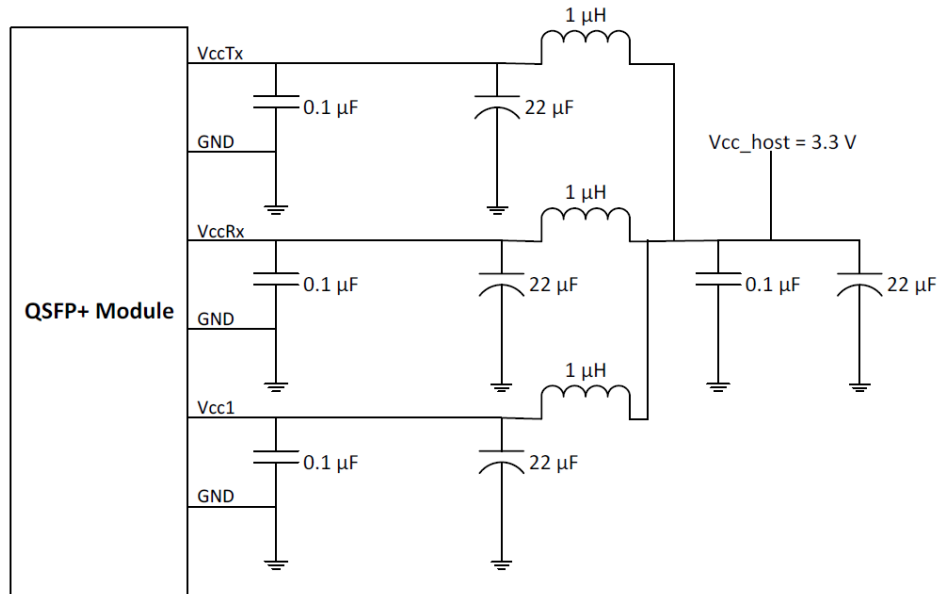

Figure 1 Recommended Interface Circuit

QSFP28 Transceiver Electrical Pad Layout

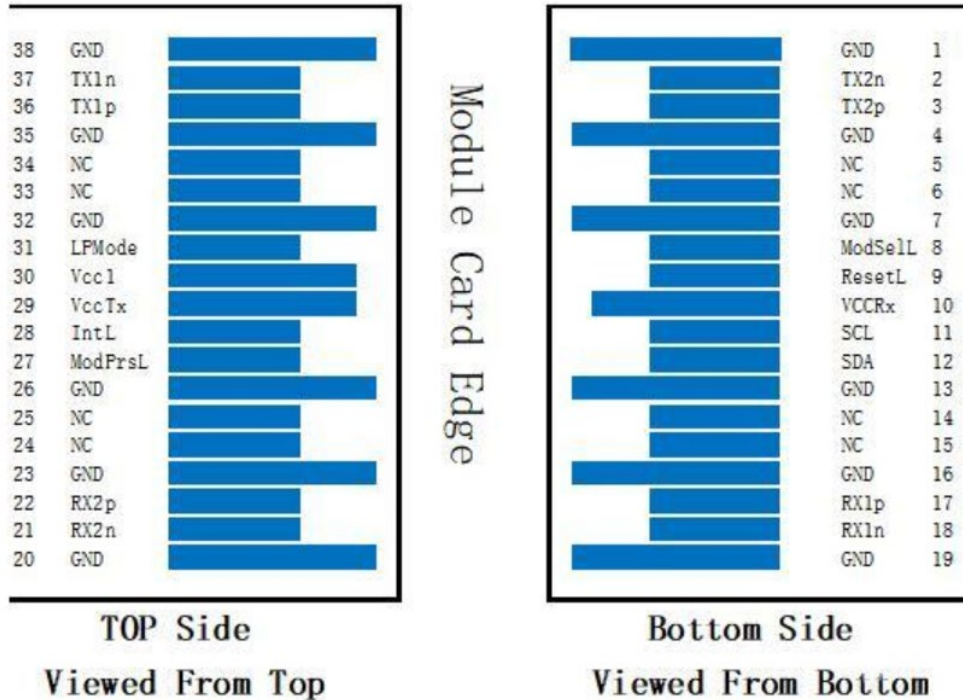

Figure 2 PIN MAP

Mechanical Specifications

For detail mechanical information, please refer to the related document of SFF-8661.

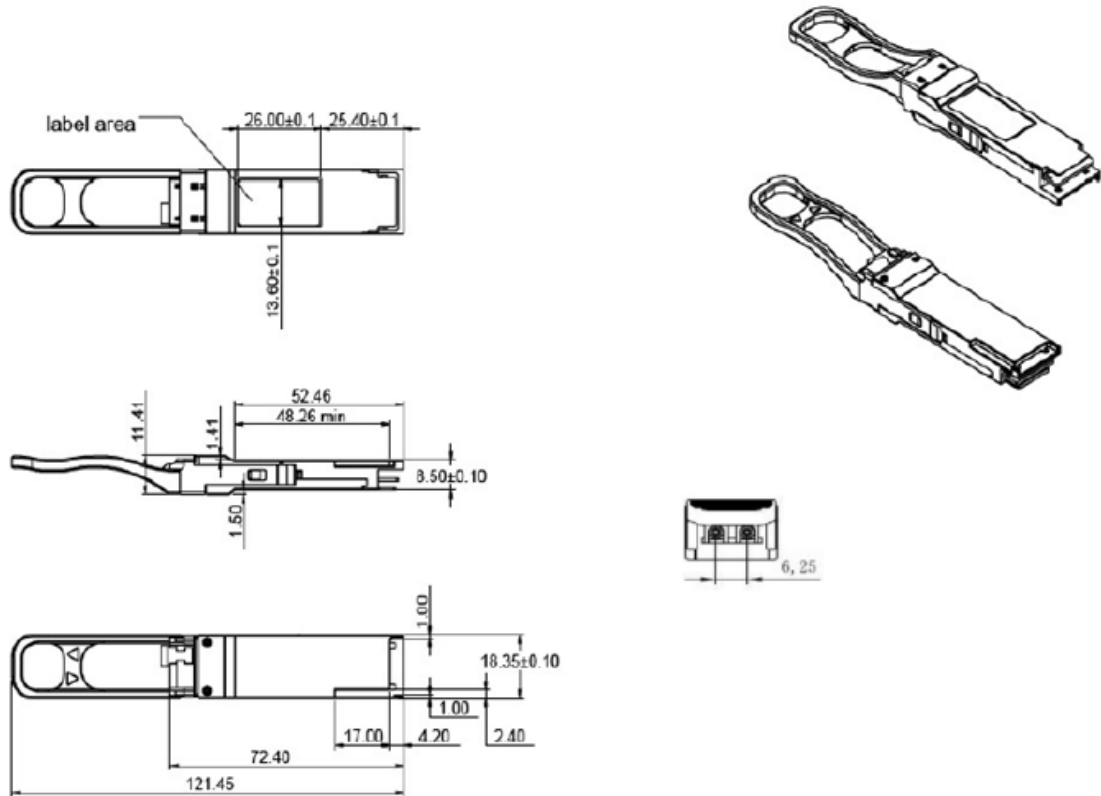

Figure 3 Mechanical

EEPROM Information

The digital diagnostic memory map specific data field defined as following. For detail EEPROM information, please refer to the related document of SFF-8636.

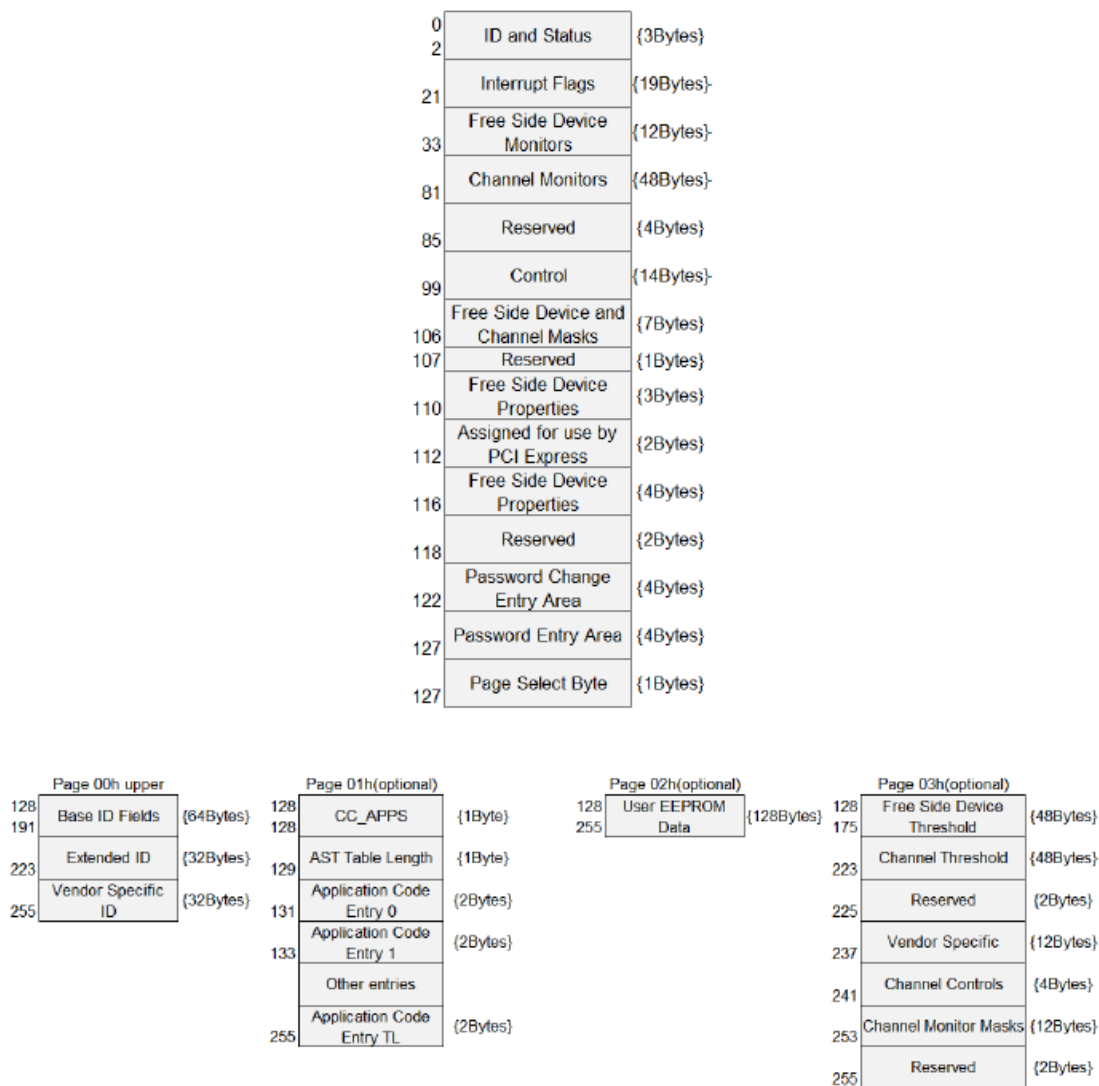

Figure 4 QSFP28 Memory Map

ESD

The QSFP28 module and host SFI contacts (High Speed Contacts) shall withstand 1000 V electrostatic discharge based on Human Body Model and all host contacts with exception of the SFI contacts (High Speed Contacts) shall withstand 2 kV electrostatic discharge based on Human Body Model. The QSFP28 module shall meet ESD requirements given in EN61000-4-2, criterion B test specification such that units are subjected to 15 kV air discharges during operation and 8 kV direct contact discharges to the case according section 5.3 in SFF-8679 REV1.5.

Laser Safety

This is a Class 1 Laser Product according to IEC 60825-1:2007. This product complies with 21 CFR 1040.10 and 1040.11 except for deviations pursuant to Laser Notice No. 50, dated (June 24, 2007).

Ordering Information

Ordering P/Ns	Description
D121ff-QLCA	10km, TX 1270nm/RX1330nm, 2*26.5625G NRZ electrical interface, 50G PAM4 at LC/UPC optical interface, QSFP28, commercial temperature
D112ff-QLCA	10km, TX 1220nm/RX1270nm, 2*26.5625G NRZ electrical interface, 50G PAM4 at LC/UPC optical interface, QSFP28, commercial temperature

Contact Us**TAIHEI BOEKI CO., LTD.**

光学機器課

〒103-0023 東京都中央区日本橋本町2-2-2

TEL 03-3270-4826 FAX 03-3245-1767

<http://www.taiheiboeki.co.jp>tokyo@taiheiboeki.co.jp

Copyright © 2020 Broadex Technologies. All rights reserved