

## 50G BASE-ER BIDI QSFP28 Optical Transceiver

### Product Features

- Supports 50GBASE-ER
- Up to 40km over SMF with KP4 FEC
- 25G EML linear transmitter
- 25G APD linear receiver
- Supports 2x26.5625Gbps host interface
- Supports 53.125Gbps optical interface
- QSFP28 MSA package with single LC connector
- I2C interface with Digital Diagnostic Monitoring
- Compliant to SFF-8636
- Single 3.3V power supply
- Maximum Power consumption 3.5W
- Operating case temperature: 0 to +70°C
- RoHS compliance, and Class 1 laser safety

### Applications

- 50GBASE-ER Ethernet Links

### Absolute Maximum Ratings

Parameter	Symbol	Unit	Min.	Typical	Max.	Notes
Storage Temperature	Ts	°C	-40		85	
Operating Case Temperature	Top	°C	0		70	
Operating Relative Humidity	RH	%	5		85	
3.3V Power Supply Voltage		V	0		3.6	
Input LVTTTL Control		V	0		VCC	
LVTTTL output DC current		mA	0		20	
Receiver Damage Threshold	Pin	dBm			-2.4	

### Recommended Operating Conditions and Power Supply Requirements

Parameter	Symbol	Unit	Min.	Typical	Max.	Notes
Operating Case Temperature	Top	°C	0		70	
Operating Relative Humidity	RH	%	5		85	
Power Supply Working Voltage		V	3.135	3.3	3.465	
Power budget (for max TDECQ)		dB			21.7	
Link Distance	D	km			40	

### Characteristics

All performance is specified at whole working temperature and conditions

Parameter	Symbol	Unit	Min.	Typical	Max.	Note
<b>Transmitter</b>						
Signaling Rate		GBd	26.5625±100ppm			
Module Format			PAM4			
TX Central Wavelength		nm	1292.21		1296.59	
			1306.29		1310.19	
Side-Mode Suppression Ratio	SMSR	dB	30			
Launch Power in OMA minus TDECQ		dBm	2			
Average Launch power	PAVG	dBm	0.4		6.6	
Optical Modulation Amplitude		dBm	3.4		7.4	
TDECQ	TDECQ	dB			3.2	
Average launch power of OFF transmitter,each lane	Poff	dB			-15	
Extinction ratio	ER	dB	6			
RIN <sub>15</sub> OMA	RIN	dB/Hz			-132	
Optical return loss tolerance	TOL	dB			15	
Transmitter reflectance	RT	dB			-26	
<b>Receiver</b>						
Signaling Rate		GBd	26.5625±100ppm			
Module Format			PAM4			
RX Central Wavelength		nm	1306.29		1310.19	
			1292.21		1296.59	
Receiver sensitivity OMA	Sens	dBm			-15.1	Note1
Stress Sensitivity OMA		dBm			-13.3	
Saturation Power (EOL)		dBm	-3.4			Note1
Stressed eye closure for PAM4(SECQ)		dB			3.2	

Notes:

Note1, For the requirement of receiver sensitivity, the value of BER is 2e-4(before FEC).

**PIN Function Definitions**

Pin No.	Symbol	Level / Logic	Description
1	GND		Ground
2	Tx2n	CML-I	Transmitter Inverted Data Input
3	Tx2p	CML-I	Transmitter Non-Inverted Data Input
4	GND		Ground
5	NC		
6	NC		
7	GND		Ground
8	ModSelL	LVTTTL-I	Module Select
9	ResetL	LVTTTL-I	Module Reset
10	Vcc Rx		+3.3V Power Supply Receiver
11	SCL		2-wire serial interface clock
12	SDA	3.3V LVCOMS-I	2-wire serial interface data
13	GND	3.3V LVCOMS-I/O	Ground
14	NC		
15	NC		
16	GND		Ground
17	Rx1p	CML-O	Receiver Non-Inverted Data Output
18	Rx1n	CML-O	Receiver Inverted Data Output
19	GND		Ground
20	GND		Ground
21	Rx2n	CML-O	Receiver Inverted Data Output
22	Rx2p	CML-O	Receiver Non-Inverted Data Output
23	GND		Ground
24	NC		
25	NC		
26	GND		Ground
27	ModPrsL	LVTTTL-O	Module Present
28	IntL	LVTTTL-O	Interrupt
29	VccTx		+3.3V Power supply transmitter
30	Vcc1		+3.3V Power supply
31	LPMODE	LVTTTL-I	Low Power Mode
32	GND		Ground
33	NC		
34	NC		
35	GND		Ground
36	Tx1p	CML-I	Transmitter Non-Inverted Data Input
37	Tx1n	CML-I	Transmitter Inverted Data Input
38	GND		Ground

**Typical Interface Circuit**

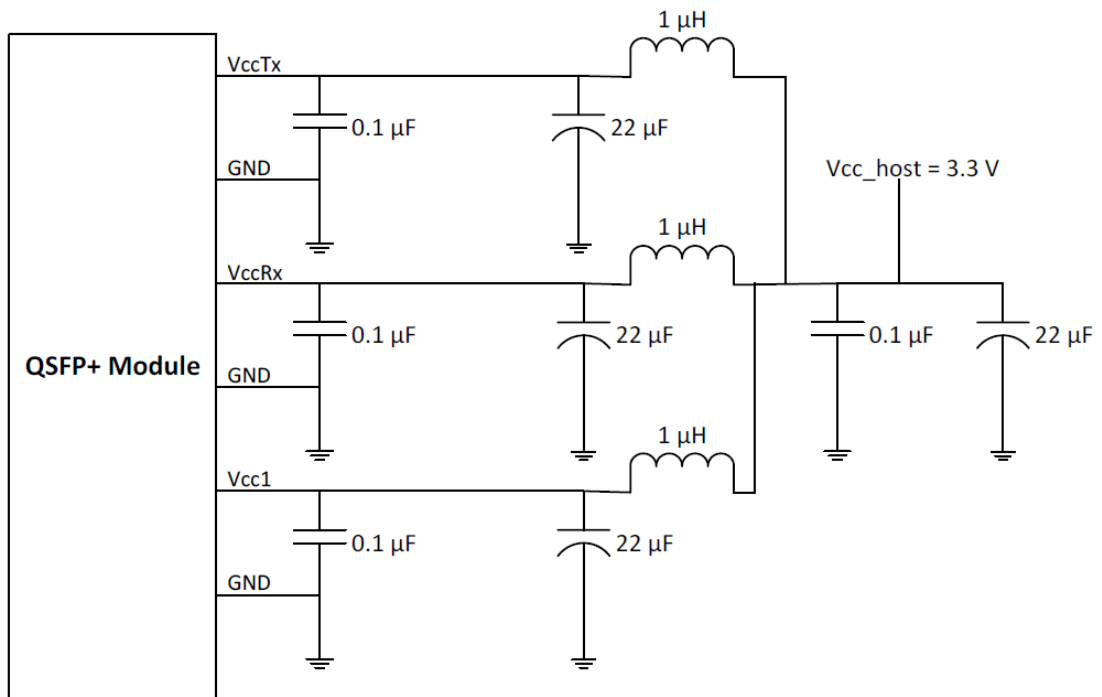

Figure 1 Recommended Interface Circuit

**QSPF28 Transceiver Electrical Pad Layout**

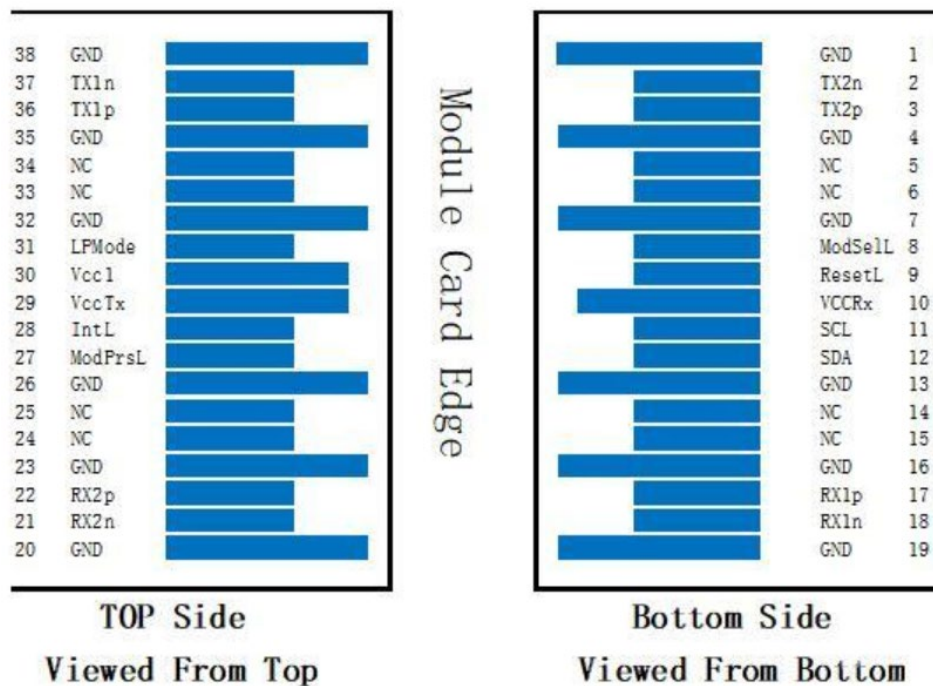

Figure 2 PIN MAP

**Mechanical Specifications**

For detail mechanical information, please refer to the related document of SFF-8661.

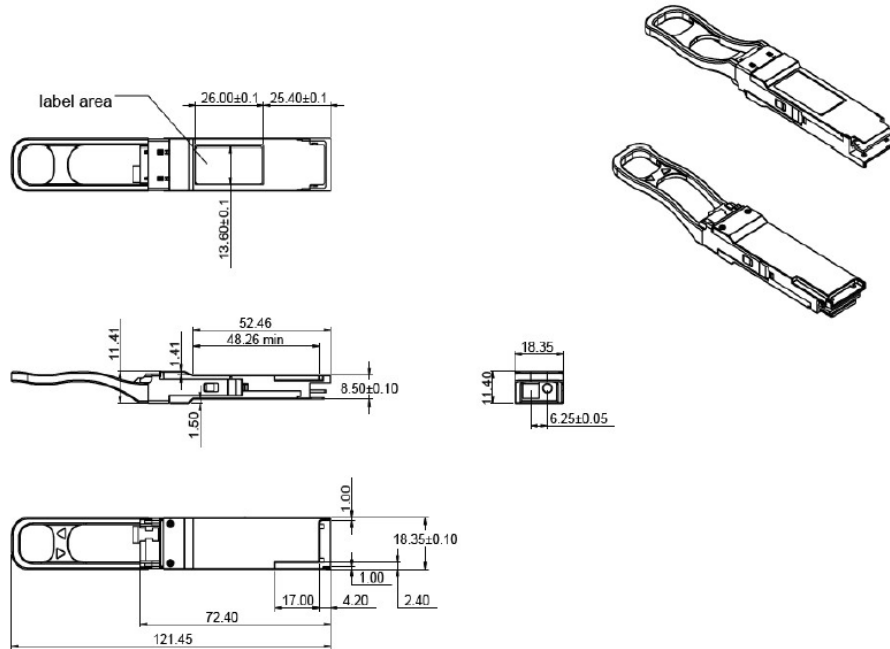

Figure 3 Outlines

### EEPROM Information

The digital diagnostic memory map specific data field defined as following. For detail EEPROM information, please refer to the related document of SFF 8472 Rev 12.0.

0	ID and Status	{3Bytes}
2		
21	Interrupt Flags	{19Bytes}
33	Free Side Device Monitors	{12Bytes}
81	Channel Monitors	{48Bytes}
85	Reserved	{4Bytes}
99	Control	{14Bytes}
106	Free Side Device and Channel Masks	{7Bytes}
107	Reserved	{1Bytes}
110	Free Side Device Properties	{3Bytes}
112	Assigned for use by PCI Express	{2Bytes}
116	Free Side Device Properties	{4Bytes}
118	Reserved	{2Bytes}
122	Password Change Entry Area	{4Bytes}
127	Password Entry Area	{4Bytes}
127	Page Select Byte	{1Bytes}

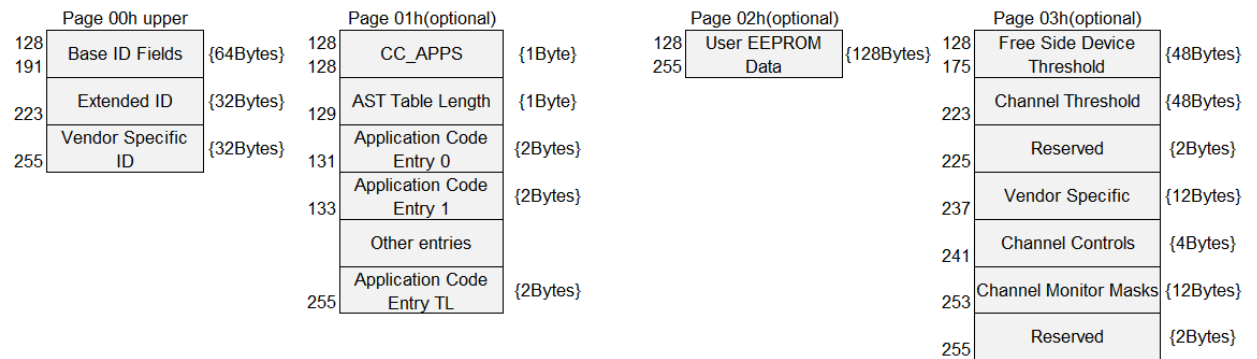

Figure 4 QSFP28 Memory Map

**EEPROM Serial ID Memory Contents (Upper page 00h)**

Data	Size	Name of Field	Description	Hex Value
Address	(Bytes)			
128	1	Identifier	QSFP28	11
129	1	Ext. Identifier	Serial ID module	CC
130	1	Connector	LC Connector	07
131-138	8	Transceiver		80 00 00 00 00 00 00 00
139	1	Encoding	PAM4	08
140	1	Nominal Bit Rate	See Byte 222	FF
141	1	Rate Select	Not compliant	00
142	1	Link Length(Standard SM Fiber)	Transceiver transmit distance,40*km	28
143	1	Link Length(OM3)	Not compliant	00
144	1	Link Length(OM2)	Not compliant	00
145	1	Link Length(OM1)	Not compliant	00
146	1	Link Length(Cooper)	Not compliant	00
147	1	Device Tech	1311nm DFB No wavelength control; cooled transmitter device APD detector Transmitter not tunable	66
148-163	16	Vendor name	"BROADEX" Vendor Name(ASCII)	42 52 4F 41 44 45 58 20 20 20 20 20 20 20 20
164	1	Electronic or optical interfaces for InfiniBand	.	00
165-167	3	Vendor OUI		00 00 00
168-183	16	Vendor PN	"D4TVff-QLCF"Part No.(ASCII)	44 34 56 54 66 66 2D 51 4C 43 46 20 20 20 20 20
184-185	2	Vendor rev		00 00
186-187	2	Wavelength	Transceiver wavelength	65 37
188-189	2	Wavelength Tolerance		00 CE
190	1	Max Case Temp	Max Case Temp 70°C	46
191	1	Check Sum	Address 128-190 Checksum	(Variable)
192	1	Link Code		00
193-195	3	Rate Select, TX Disable, TX Fault, LOS, Warning indicators		07 F5 DA
196-211	16	Vendor SN	Serial Number of transceiver (ASCII).	SN(Variable)
212-219	8	Date code	Manufactory Date Code.	DC(Variable)
220	1	Diagnostic Monitoring Type	Average Power	0C
221	1	Enhanced Options		10
222	1	Extended bit rate	Nominal bit rate per lane, units of 250 Mbps	D5
223	1	Check Sum	Address 192-222	(Variable)
224-255		Reserved	Filled by zero	Read only

**EEPROM DDM Alarm & Warning Threshold (Upper page 03h)**

Data	Size	Name of Field	Hex Value	Description
Address	(Bytes)			
128-129	2	Temperature High Alarm	50 00	80°C
130-131	2	Temperature Low Alarm	F6 00	-10°C
132-133	2	Temperature High Warning	46 00	70°C
134-135	2	Temperature Low Warning	00 00	0°C
144-145	2	Vcc High Alarm	8D CC	3.63V
146-147	2	Vcc Low Alarm	74 04	2.97V
148-149	2	Vcc High Warning	87 5A	3.465V
150-151	2	Vcc Low Warning	7A 76	3.135V
176-177	2	RX Power High Alarm	23 A0	-0.4dBm
178-179	2	RX Power Low Alarm	00 57	-20.6dBm
180-181	2	RX Power High Warning	11 DA	-3.401dBm
182-183	2	RX Power Low Warning	00 AD	-17.62dBm
184-185	2	Bias High Alarm	FD E8	130mA
186-187	2	Bias Low Alarm	13 88	10mA
188-189	2	Bias High Warning	EA 60	120mA
190-191	2	Bias Low Warning	1D 4C	15mA
192-193	2	TX Power High Alarm	FF B7	8.16dBm
194-195	2	TX Power Low Alarm	15 77	-2.6dBm
196-197	2	TX Power High Warning	B2 8C	6.6dBm
198-199	2	TX Power Low Warning	2A D4	0.4dBm

**DDMI Requirement and LSB Definition**

Parameter	Unit	Error	NOTES
Temperature	°C	±3°C	1LSB=1/256°C
Vcc Voltage	V	±5%	1LSB=0.1mV
TX Bias Current	mA	±10%	1LSB=2uA
TX Power	dB	±3dB	1LSB=0.1uW
RX Power	dB	±3dB	1LSB=0.1uW

**ESD**

The QSFP28 module and host SFI contacts (High Speed Contacts) shall withstand 1000 V electrostatic discharge based on Human Body Model and all host contacts with exception of the SFI contacts (High Speed Contacts) shall withstand 2 kV electrostatic discharge based on Human Body Model. The QSFP28 module shall meet ESD requirements given in EN61000-4-2, criterion B test specification such that units are subjected to 15 kV air discharges during operation and 8 kV direct contact discharges to the case according to section 5.3 in SFF-8679 REV1.5.



**Laser Safety**

This is a Class 1 Laser Product according to IEC 60825-1:2007. This product complies with 21 CFR 1040.10 and 1040.11 except for deviations pursuant to Laser Notice No. 50, dated (June 24, 2007).

**Ordering Information**

Ordering P/Ns	Description
D4TVff-QLCF	50GBASE-ER BIDI 1295TX/1309RX SM PMA4 QSFP28 Transceiver
D4VTff-QLCF	50GBASE-ER BIDI 1309TX/1295RX SM PMA4 QSFP28 Transceiver

**Contact Us** **太平貿易株式会社**  
**TAIHEI BOEKI CO., LTD.**

光学機器課

〒103-0023 東京都中央区日本橋本町2-2-2

TEL 03-3270-4826 FAX 03-3245-1767

<http://www.taiheiboeki.co.jp>[tokyo@taiheiboeki.co.jp](mailto:tokyo@taiheiboeki.co.jp)

Copyright © 2020 Broadex Technologies. All rights reserved