

40GBASE-SR QSFP+ Optical Transceiver

Product Features

- Supports 40GBASE-SR
- Up to 100m over MMF (OM3) and 300m over MMF (OM4)
- VCSEL transmitter and PIN receiver
- Supports 4x10Gbps Host Interface
- Supports 41.25Gbps optical Interface
- QSFP+ MSA with Duplex LC Connector
- I2C management interface with Digital Diagnostic Monitoring
- Compliant to SFF-8636 Rev2.7, SFF-8436 Rev 4.8, SFF-8635 Rev0.6, SFF-8679 Rev1.7 and SFF-8661 Rev2.3
- Single 3.3V power supply
- Operating case temperature: 0~70°C
- Maximum power dissipation 3.5W
- RoHS6 compliance

Application

- 40GBASE-SR Ethernet Links

Absolute Maximum Ratings

Parameter	Unit	Min.	Typical	Max.
Storage Temperature	°C	-40		85
Operating Case Temperature	°C	0		70
Operating Relative Humidity	%	5		85
Power Supply not Damaged Voltage	V	0		3.6

Recommended Operating Conditions

Parameter	Unit	Min.	Typical	Max.
Operating Case Temperature	°C	0		70
Operating Relative Humidity	%	5		85
Power Supply Working Voltage	V	3.135	3.3	3.465
Power Consumption	W			3.5

Characteristics

All performance is specified at whole working temperature and conditions

Parameter	Unit	Min.	Typical	Max.
Transmitter				
Signaling Rate	GBd	20.625±100ppm		
Module Format		PAM4		
TX Central Wavelength	nm	840	850	860
Side-Mode Suppression Ratio	dB	30		
RMS spectral width	nm			0.65
Average launch power	dBm	-2		2.4
TDECQ	dB			3.5
Average launch power of OFF transmitter	dB			-30
Extinction ratio	dB	3.0		
RIN ₁₂ OMA	dB/Hz			-128
Optical return loss tolerance	dB			12
Receiver				
Signaling Rate	GBd	20.625±100ppm		
Module Format		PAM4		
RX Central Wavelength	nm	840	850	860
Saturation power	dBm	2.4		
Average receive power	dBm	-8		2.4
Max Input power	dBm	3.4		
Receiver reflectance	dB			-12
LOS Assert	dBm	-25		
LOS De-assert	dBm			-12
LOS Hysteresis	dB	0.5		
Power Noise and Ripple	mV			60
Supply Current	mA			1130
Maximum peak Current	mA			1400
Input differential impedance	Ω	90	100	110
Differential data input swing	mV	120		1200
Differential data output swing	mV	300		850

PIN Function Definitions

Pin No.	Symbol	Description
1	GND	Ground
2	Tx2n	Transmitter Inverted Data Input
3	Tx2p	Transmitter Non-Inverted Data Input
4	GND	Ground
5	Tx4n	Transmitter Inverted Data Input
6	Tx4p	Transmitter Non-Inverted Data Input
7	GND	Ground
8	ModSelL	Module Select
9	ResetL	Module Reset
10	Vcc Rx	+3.3V Power Supply Receiver
11	SCL	2-wire serial interface clock
12	SDA	2-wire serial interface data
13	GND	Ground
14	Rx3p	Receiver Non-Inverted Data Output
15	Rx3n	Receiver Inverted Data Output
16	GND	Ground
17	Rx1p	Receiver Non-Inverted Data Output
18	Rx1n	Receiver Inverted Data Output
19	GND	Ground
20	GND	Ground
21	Rx2n	Receiver Inverted Data Output
22	Rx2p	Receiver Non-Inverted Data Output
23	GND	Ground
24	Rx4n	Receiver Inverted Data Output
25	Rx4p	Receiver Non-Inverted Data Output
26	GND	Ground
27	ModPrsL	Module Present
28	IntL	Interrupt
29	VccTx	+3.3V Power supply transmitter
30	Vcc1	+3.3V Power supply
31	LPMODE	Low Power Mode
32	GND	Ground
33	Tx3p	Transmitter Non-Inverted Data Input
34	Tx3n	Transmitter Inverted Data Input
35	GND	Ground
36	Tx1p	Transmitter Non-Inverted Data Input
37	Tx1n	Transmitter Inverted Data Input
38	GND	Ground

Typical Interface Circuit

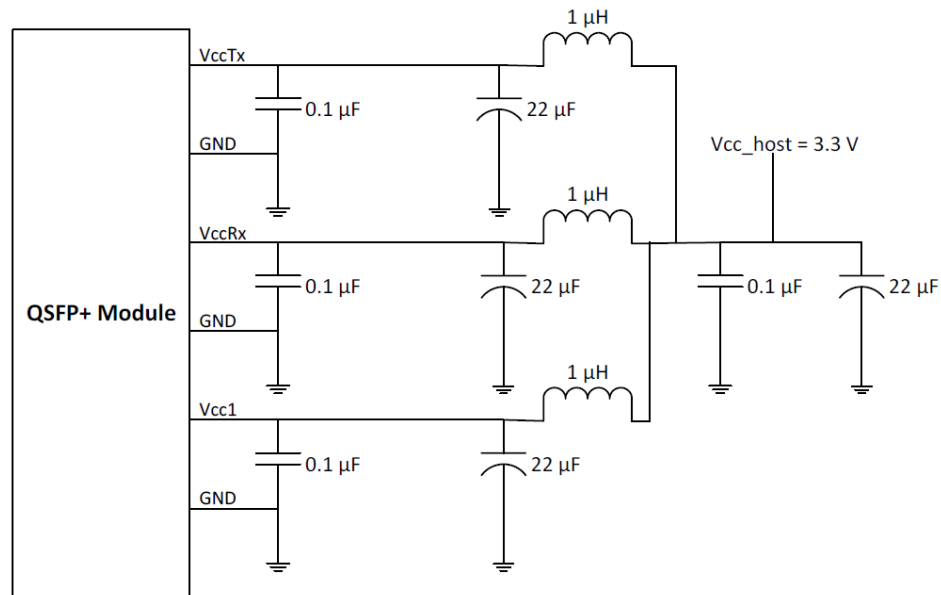

Figure 1 Recommended Interface Circuit

QSPF+ Transceiver Electrical Pad Layout

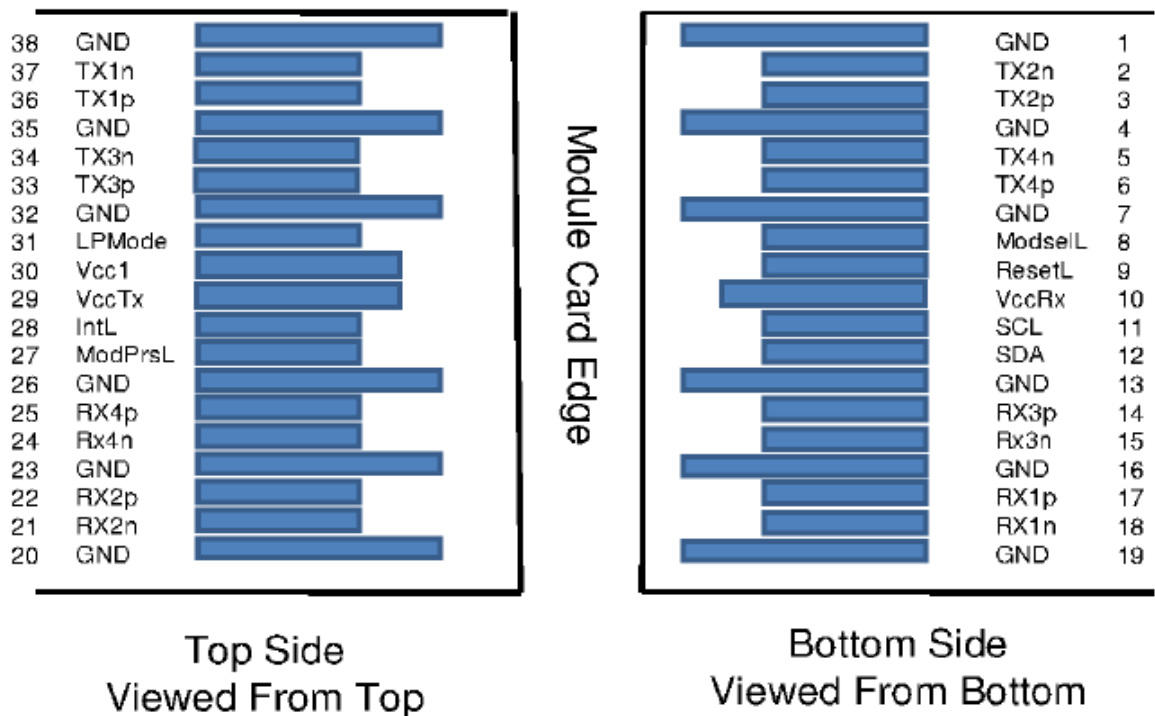

Figure 2 PIN MAP

Mechanical Specifications

For detail mechanical information, please refer to the related document of SFF-8436.

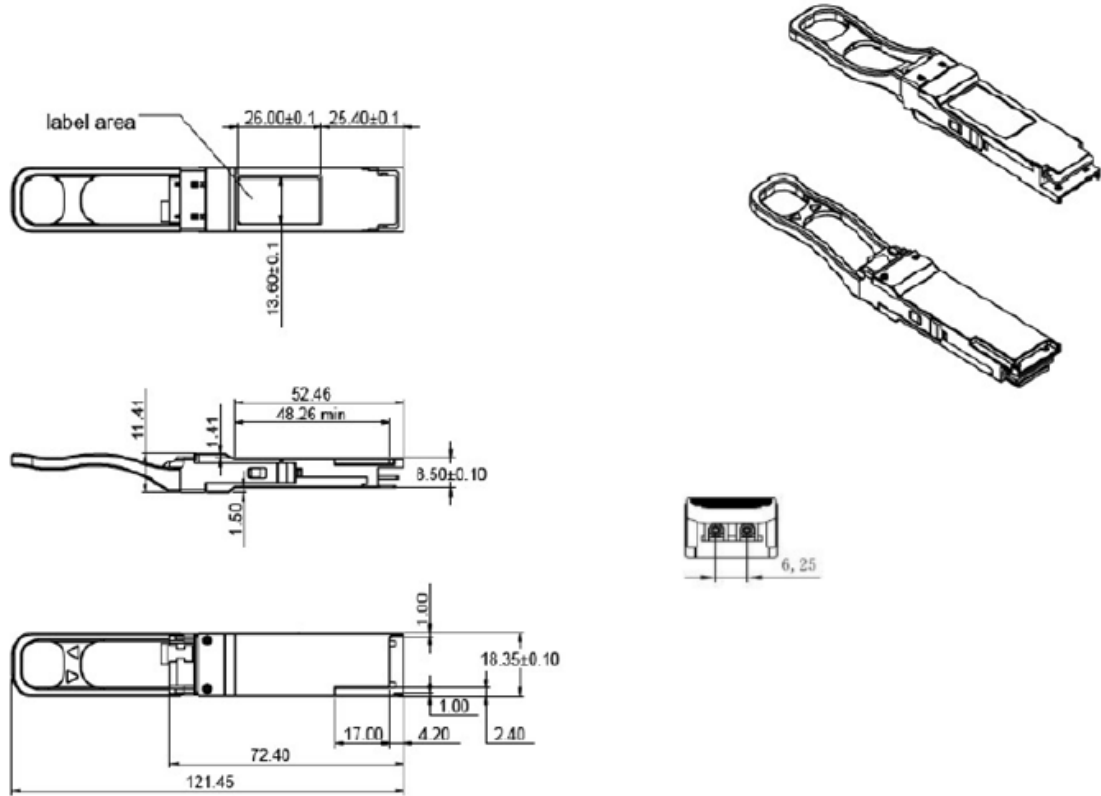

Figure 3 Mechanical

EEPROM Information

The digital diagnostic memory map specific data field defined as following. For detail EEPROM information, please refer to the related document of SFF 8636 Rev 2.7.

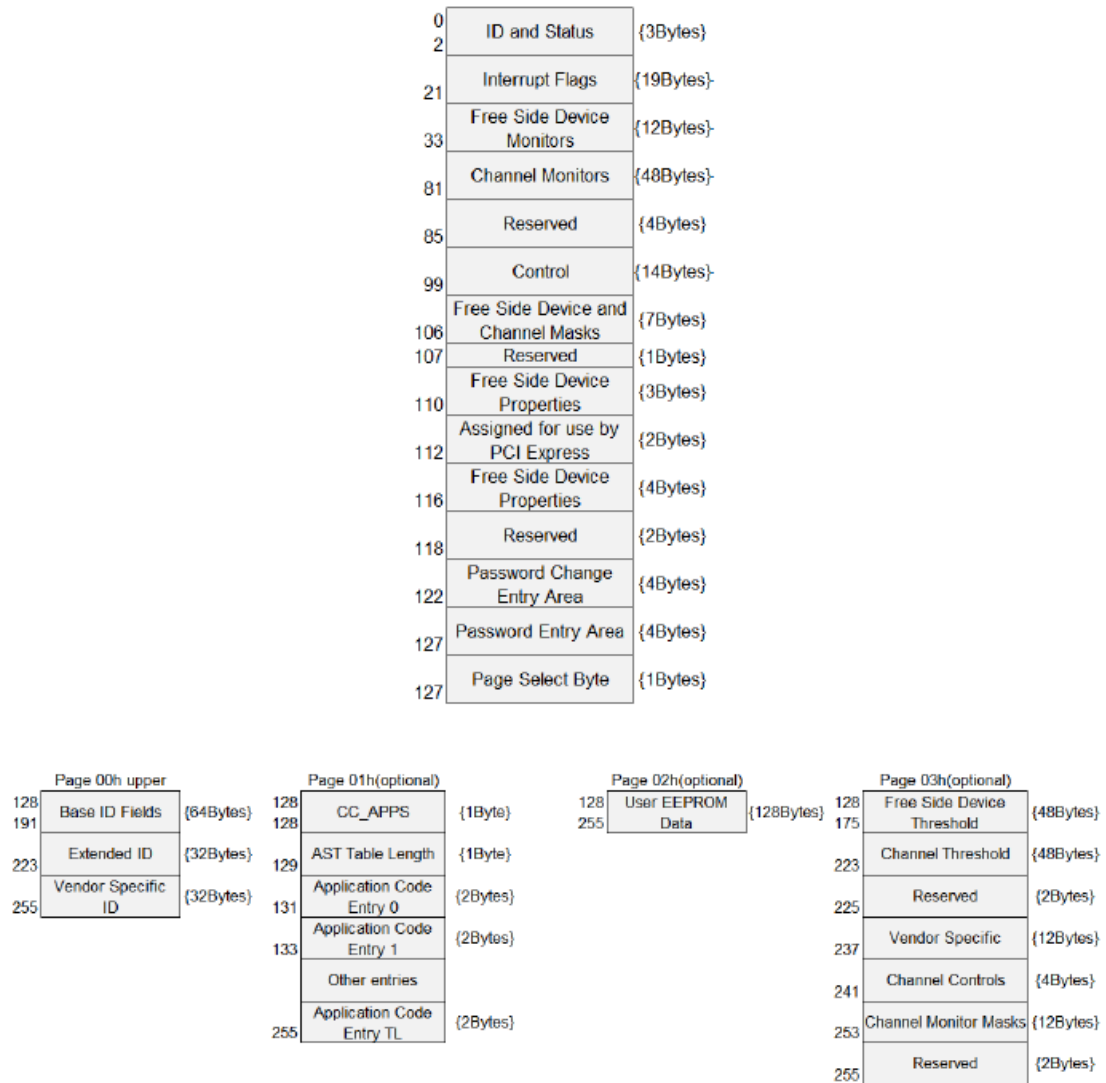

Figure 4 QSFP28 Memory Map

DDMI Requirements

Parameter	Unit	Requirement
Temperature	°C	±3
Vcc Voltage	V	±5%
TX Bias Current	mA	±10%
TX Power	dB	±3
RX Power	dB	±3

ESD

The QSFP+ module and host SFI contacts (High Speed Contacts) shall withstand 1000 V electrostatic discharge based on Human Body Model and all host contacts with exception of the SFI contacts (High Speed Contacts) shall withstand 2 kV electrostatic discharge based on Human Body Model. The QSFP+ module shall meet ESD requirements given in EN61000-4-2, criterion B test specification such that units are subjected to 15 kV air discharges during operation and 8 kV direct contact discharges to the case according to section 5.3 in SFF-8679 REV1.5.

Laser Safety

This is a Class 1 Laser Product according to IEC 60825-1:2007. This product complies with 21 CFR 1040.10 and 1040.11 except for deviations pursuant to Laser Notice No. 50, dated (June 24, 2007).

Ordering Information

Ordering P/Ns	Description
DH88kk-QLCA	150m, 850nm, 4*10G NRZ electrical interface, 1*40G PAM4 at LC/UPC optical interface, QSFP+, commercial temperature

Contact Us**TAIHEI BOEKI CO., LTD.**

光学機器課

〒103-0023 東京都中央区日本橋本町2-2-2

TEL 03-3270-4826 FAX 03-3245-1767

<http://www.taiheiboeki.co.jp>tokyo@taiheiboeki.co.jp**Copyright © 2020 Broadex Technologies. All rights reserved**