

QSFP+ 40G SR4 Transceiver

Product Features

- 4x10Gb/s, 850nm, Compliant to the IEEE 802.3ba(40GBASE-SR4)
- Compliant to the QSFP+ MSA SFF-8436
- Built-in digital diagnostic functions
- VCSEL array transmitter and PIN array receiver
- Single +3.3V power supply, and maximum 1.5W operation power for QSFP+
- Operation case temperature of 0~70°C
- Operating Data rate: up to 10.3125G for each lane
- RoHS6 compliance, and Class 1 laser safety
- Application: 10/40G Ethernet, 2/4/8G Fiber Channel, Infiniband /QDR
- Transmission distance up to 100m (OM3) and 150m (OM4) optional

Operating Condition

Parameter	Unit	Min.	Typical	Max.
Storage Temperature	°C	-10		85
Operating Case Temp for C-temp	°C	0		70
Power Supply Voltage	V	3.135	3.3	3.465
Power Consumption (QSFP+)	W			1.5
Bit Rate	Gbps	1.25	10.3125	

Electrical Characteristics

Parameter	Unit	Min.	Typical	Max.	Note
Transmitter					
Data Input Swing Differential/TX	mV	200	-	1600	
Date Differential Impedance	Ω	90	100	110	
Receiver					
Data Output Swing Differential/RX	mV	350	-	1000	
Date Differential Impedance	Ω	90	100	110	

Optical Characteristics

All performance is specified at whole working temperature and conditions (QSFP+)

Parameter	Unit	Min.	Typical	Max.	Note
Transmitter (4X10G)					
TX Central Wavelength	nm	840	850	860	
Spectral Width (RMS)	nm			0.65	
Average Launch Power, each lane	dBm	-7.6		2.4	
Optical Modulation Amplitude (OMA)	dBm	-5.6		3.0	
Average Launch power Tx_off	dBm	-	-	-30	
Extinction Ratio	dB	3	-	-	
Optical Return Loss Tolerance	dB	-	-	12	1
Encircled Flux	dBm	> 86% at 19 um < 30% at 4.5 um			1
Transmitter eye mask definition {X1, X2, X3, Y1, Y2, Y3} Hit ratio 5×10^{-5} hits per sample	—	{0.23, 0.34, 0.43, 0.27, 0.35, 0.4}			
Receiver (4X10G)					
RX Central Wavelength	nm	840	850	860	
Average Receiver Power per lane	dBm	-9.9		2.4	
Sensitivity (Average power) @BER=E-12	dBm	-	-	-10.2	2
Stressed Receiver Sensitivity (OMA) per Lane	dBm		-	-5.4	2
Overload Input Optical Power	dBm	2.5	-	-	
LOS Assert	dBm	-30	-	-	
LOS De-Assert	dBm	-	-	-12	
LOS Hysteresis	dB	0.5	-	-	

Note:

1. Coupled into 50/125 MMF.
2. Measured with PRBS 2³¹-1 test pattern @10.3125Gbps.BER=E-12

Optical Interface

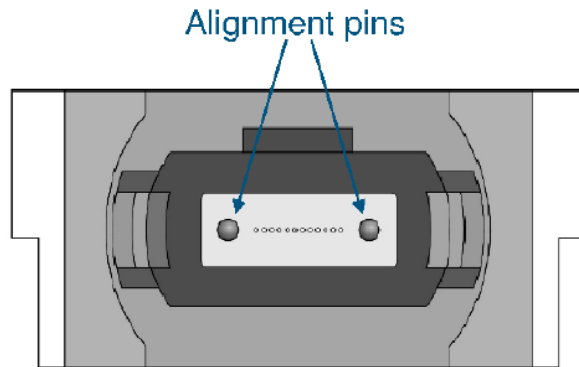

Transmit Channels: 1 2 3 4
 Unused positions: x x x x
 Receive Channels: 4 3 2 1

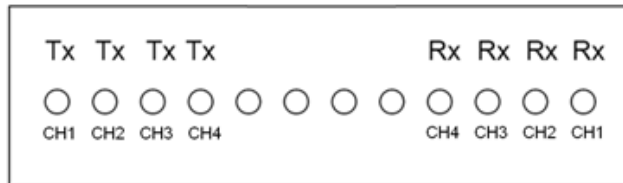

PIN Definition
1, QSFP+

Pin No.	Symbol	Level / Logic	Description
1	GND		Module Ground
2	Tx2n	CML-I	Transmitter Inverted Data Input
3	Tx2p	CML-I	Transmitter Non-Inverted Data Input
4	GND		Module Ground
5	Tx4n	CML-I	Transmitter Inverted Data Input
6	Tx4p	CML-I	Transmitter Non-Inverted Data Input
7	GND		Module Ground
8	ModSelL	LVTTL-I	Module Select
9	ResetL	LVTTL-I	Module Reset
10	VccRx		+3.3V Power Supply for Receiver
11	SCL	LVTTL-I	2-Wire Serial Interface Clock
12	SDA	LVTTL-I/O	2-Wire Serial Interface Data Line
13	GND		Module Ground
14	Rx3p	CML-O	Receiver Non-Inverted Data Output
15	Rx3n	CML-O	Receiver Inverted Data Output
16	GND		Module Ground
17	Rx1p	CML-O	Receiver Non-Inverted Data Output
18	Rx1n	CML-O	Receiver Inverted Data Output
19	GND		Module Ground
20	GND		Module Ground
21	Rx2n	CML-O	Receiver Inverted Data Output
22	Rx2p	CML-O	Receiver Non-Inverted Data Output
23	GND		Module Ground
24	Rx4n	CML-O	Receiver Inverted Data Output
25	Rx4p	CML-O	Receiver Non-Inverted Data Output
26	GND		Module Ground
27	ModPrsL	LVTTL-O	Module Present
28	IntL	LVTTL-O	Interrupt
29	VccTx		+3.3V Power Supply for Transmitter
30	Vcc1		+3.3V Power Supply
31	LPMODE	LVTTL-I	Low Power Mode
32	GND		Module Ground
33	Tx3p	CML-I	Transmitter Non-Inverted Data Input
34	Tx3n	CML-I	Transmitter Inverted Data Input
35	GND		Module Ground
36	Tx1p	CML-I	Transmitter Non-Inverted Data Input
37	Tx1n	CML-I	Transmitter Inverted Data Input
38	GND		Module Ground

Notes: 1: GND is the symbol for signal and supply (power) common for the QSFP+ module. All are common within the QSFP+ module and all module voltages are referenced to this potential unless otherwise noted. Connect these directly to the host board signal-common ground plane.

2: Vcc Rx, Vcc1 and Vcc Tx are the receiver and transmitter power supplies and shall be applied concurrently. Vcc Rx, Vcc1 and Vcc Tx may be internally connected within the QSFP+ Module in any combination. The connector pins are each rated for a maximum current of 500mA.

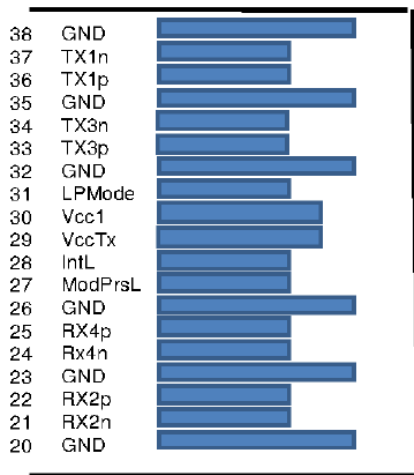
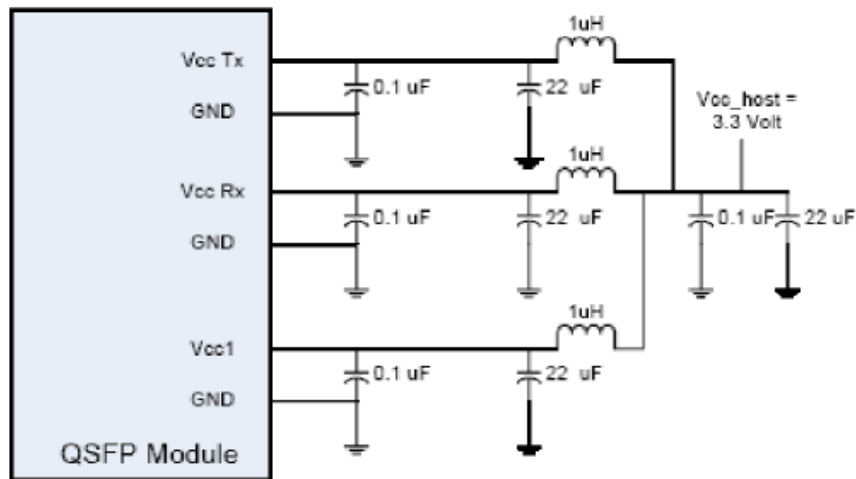

Top Side
Viewed From Top

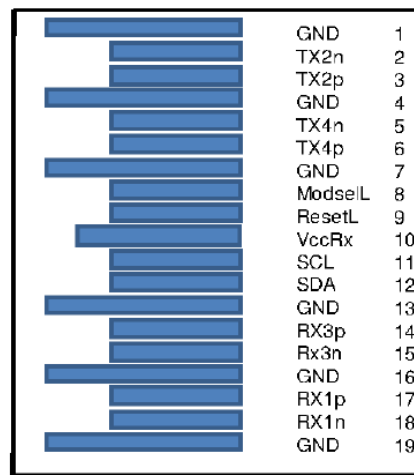

Bottom Side
Viewed From Bottom

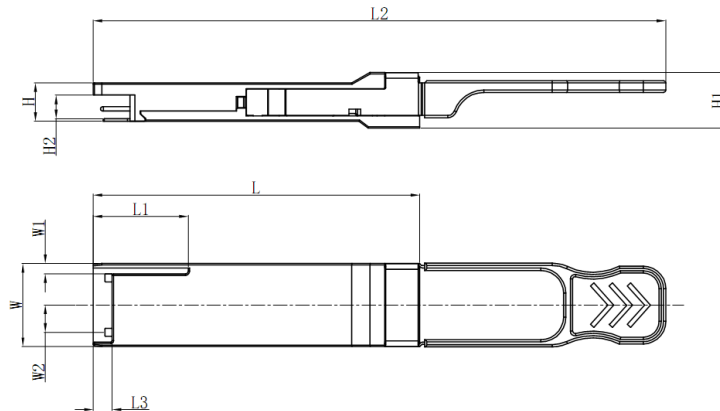
OUTLINES

Unit mm

	L	L1	L2	L3	W	W1	W2	H	H1	H2
Max	72.2	-	128	4.35	18.45	-	6.2	8.6	12.0	5.35
Type	72.0	-	-	4.20	18.35	-	-	8.5	11.8	5.2
Min	68.8	16.5	124	4.05	18.25	2.2	5.8	8.4	11.6	5.05

Ordering Information

Ordering P/Ns	Description
DH88kk-QMCA	4x10G QSFP+, 850nm, MMF, MPO, 100m, Commercial temperature.

Contact Us

太平貿易株式会社
TAIHEI BOEKI CO., LTD.

光学機器課

〒103-0023 東京都中央区日本橋本町2-2-2

TEL 03-3270-4826 FAX 03-3245-1767

<http://www.taiheiboeki.co.jp>
tokyo@taiheiboeki.co.jp

Copyright © 2020 Broadex Technologies. All rights reserved