

## 25G SFP28 SR Optical Transceiver

### Product Features

- 25.78125Gb/s, 850nm, Compliant to IEEE802.3by 25GBASE-SR
- Compliant to the SFF-8472, SFF-8431 and SFF-8432
- Built-in digital diagnostic functions
- VCSEL transmitter and PIN receiver
- Duplex LC connector
- Single +3.3V power supply
- Maximum power dissipation: 1W
- Operation case temperature: 0 to 70°C
- Maximum link length of 70m on OM3 MMF and 100m on OM4 MMF
- RoHS6 compliant

### Applications

- 25G Ethernet
- InfiniBand & Fiber channel
- Switches, Routers, and HBAs
- Enterprise & Datacenter Networking & Storage

### Absolute Maximum Ratings

Parameter	Unit	Min.	Typical	Max.	Notes
Storage Temperature	°C	-40		85	
Operating Relative Humidity	%			85	
Power Supply not Damaged Voltage	V	-0.5		3.63	

### Recommended Operating Conditions

Parameter	Unit	Min.	Typical	Max.	Notes
Operating Case Temp	°C	0		70	
Power Supply Voltage	V	3.135	3.3	3.465	
Power Consumption	W			1.0	
Bit Rate	Gbps	8.5	25.78125		

### Optical Characteristics

All performance is defined over the Recommended Operating Environment unless otherwise specified.

Parameter	Unit	Min.	Typical	Max.	Note
<b>Transmitter</b>					
TX Central Wavelength	nm	840	850	860	
Spectral Width (RMS)	nm			0.65	
Average Launch Optical Power	dBm	-8.4		2.4	
Optical Modulation Amplitude (OMA)	dBm	-6.4		3	
Average Launch power Tx_off	dBm			-30	
Extinction Ratio	dB	2			
Transmitter eye mask definition{X1,X2,X3,Y1,Y2,Y3} Hit ratio 1.5 x 10 <sup>3</sup> hits per sample			{0.3,0.38,0.45,0.35,0.41,0.5}		
<b>Receiver</b>					
RX Central Wavelength	nm	840	850	860	
Average Receiver Power	dBm	-10.3		2.4	
Receiver Power (OMA)	dBm			3.0	
Stressed Receiver sensitivity (OMA)	dBm	-5.2			
Optical Return Loss	dB			-12	
Overload Input Optical Power	dBm	2.4			
LOS Assert	dBm	-30			
LOS De-Assert	dBm			-12	
LOS Hysteresis	dB	0.5			

### Electrical Specifications

Parameter	Unit	Min.	Typical	Max.	Note
<b>Transmitter</b>					
Transmitter Differential Input Impedance	ohm	90	100	110	
Transmitter Differential Input Voltage	mV	200		1600	
<b>Receiver</b>					
Receiver Differential Input Impedance	ohm	90	100	110	
Receiver Differential Input Voltage	mV	400		800	

**PIN Function Definitions**

Pin No.	Symbol	Level / Logic	Description
1	VeeT		Module Transmitter Ground
2	Tx_Fault	LVTTTL-O	Module Transmitter Fault Indication
3	Tx_DIS	LVTTTL-I	Transmitter Disable; Active High Disable Transmitter Output
4	SDA	LVTTTL-I	2-Wire Serial Interface Data Line
5	SCL	LVTTTL-I/O	2-Wire Serial Interface Clock
6	MOD_ABS	LVTTTL-O	Module Absent, connected to ground in the module
7	RS0		Rate Select 0, optionally controls SFP28 module receiver
8	RX_LOS	LVTTTL-O	Loss of Receiver Signal Indication
9	RS1		Rate Select 1, optionally controls SFP28 module transmitter
10	VeeR		Module Receiver Ground
11	VeeR		Module Receiver Ground
12	RD-	CML-O	Receiver Inverted Data Output
13	RD+	CML-O	Receiver Non-Inverted Data Output
14	VeeR		Module Receiver Ground
15	VccR		Module Receiver 3.3V Supply
16	VccT		Module Transmitter 3.3V Supply
17	VeeT		Module Transmitter Ground
18	TD+	CML-I	Transmitter Non-Inverted Data Input
19	TD-	CML-I	Transmitter Inverted Data Input
20	VeeT		Module Transmitter Ground

**Typical Interface Circuit**

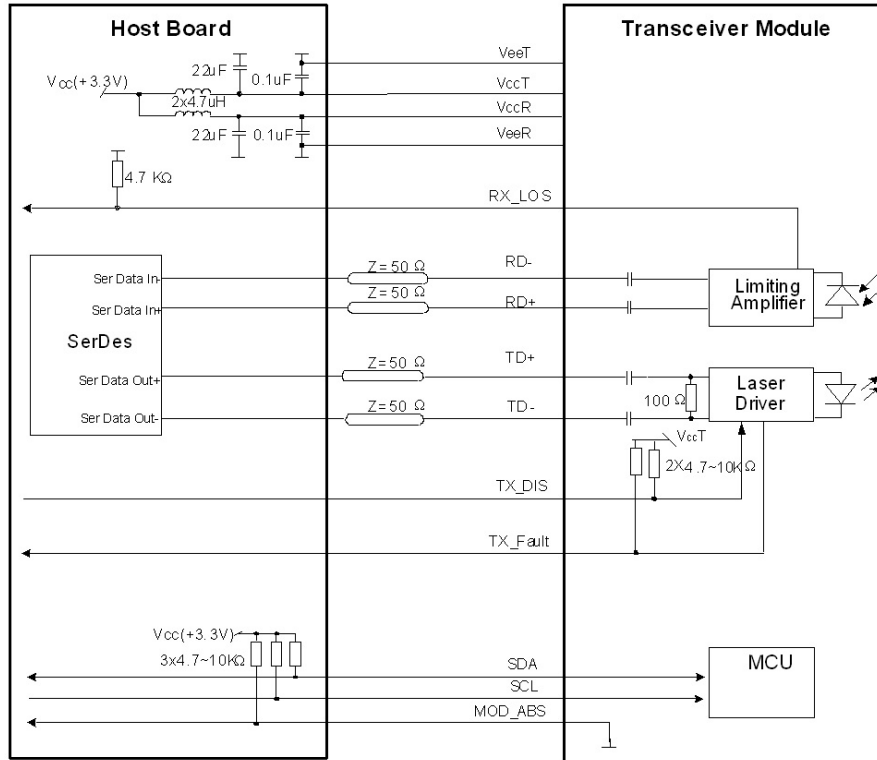

**Electrical Pad Layout**

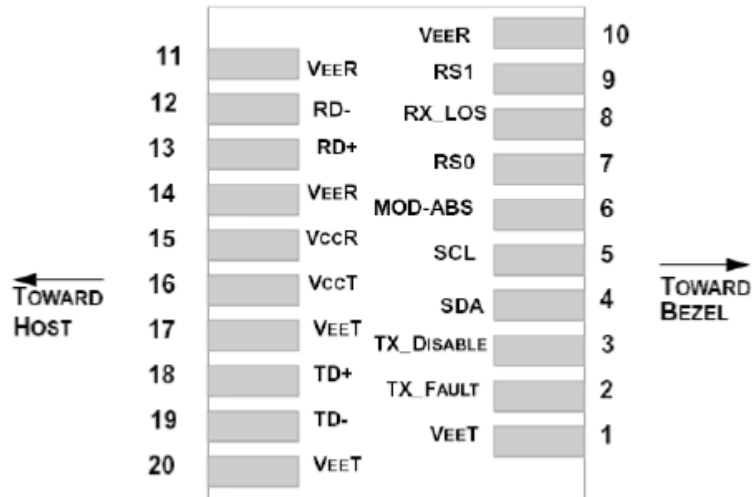

**Mechanical Specifications**

For detail mechanical information, please refer to the related document of SFF-8432.

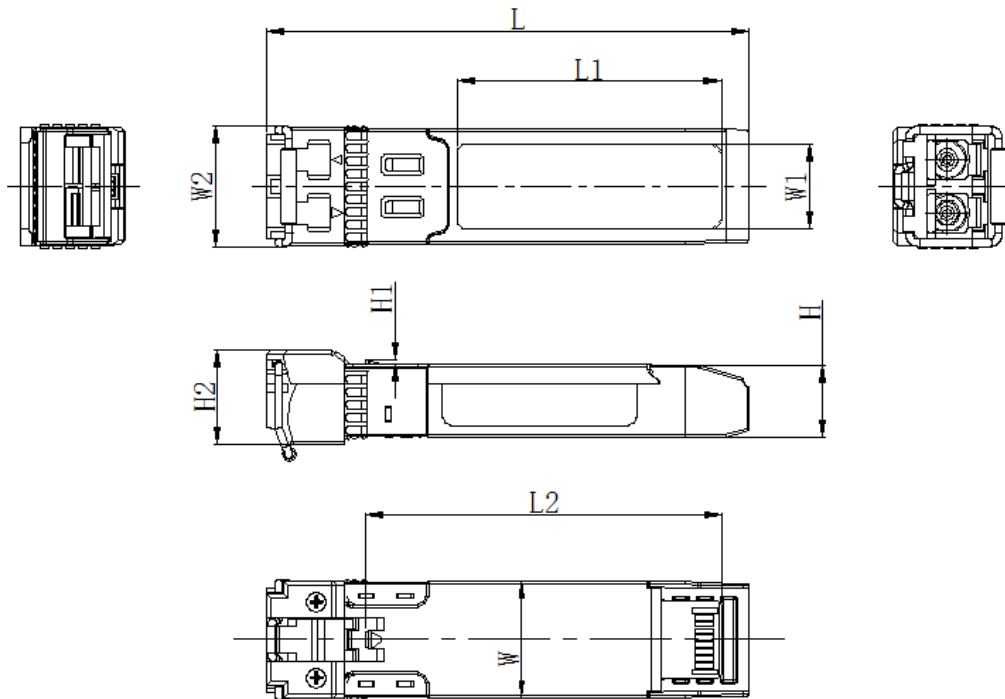

Unit: mm

	L	L1	L2	W	W1	W2	H	H1	H2
MAX	56.9	31.2	41.95	13.8	10.2	14.5	8.7	0.55	11.5
Typical	56.7	31.0	41.80	13.7	10.0	14.3	8.6	0.5	11.3
MIN	56.5	30.8	41.65	13.6	9.8	14.1	8.5	0.45	11.1

### EEPROM Information

The digital diagnostic memory map specific data field define as following. For detail EEPROM information, please refer to the related document of SFF 8472 Rev 12.0.

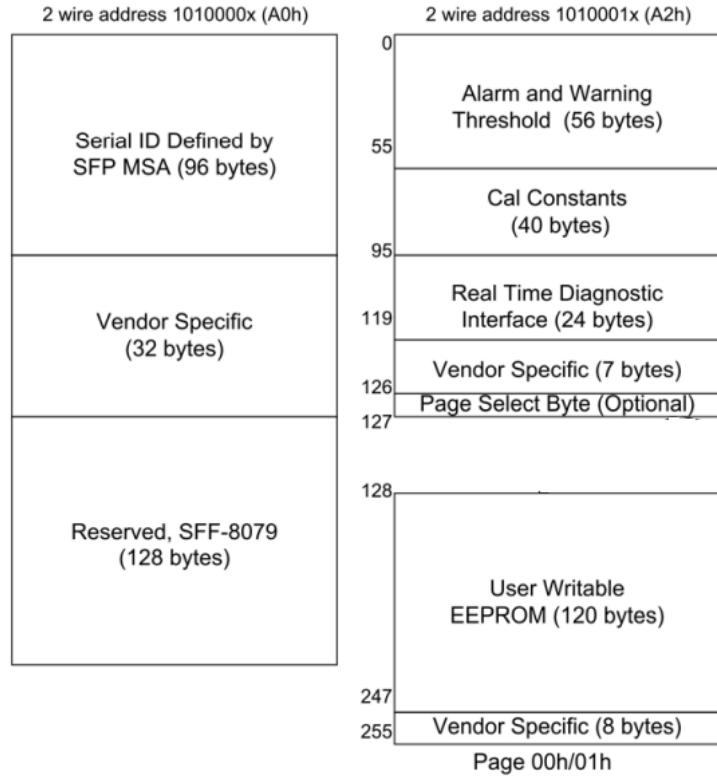

### ESD

The transceiver and host SFI contacts (High Speed Contacts) shall withstand 1kV electrostatic discharge based on Human Body Model and all host contacts with exception of the SFI contacts (High Speed Contacts) shall withstand 2kV electrostatic discharge based on Human Body Model. The SFP+ module shall meet ESD requirements given in EN61000-4-2, criterion B test specification such that units are subjected to 15kV air discharges during operation and 8kV direct contact discharges to the case per section 2.9 in SFF-8431 REV4.1. However, normal ESD precautions are still required during the handling of this module. This transceiver is shipped in ESD protective packaging. It should be removed from the packaging and handled only in an ESD protected environment.

### Laser Safty

This is a Class 1 Laser Product according to IEC 60825-1:2007. This product complies with 21 CFR 1040.10 and 1040.11 except for deviations pursuant to Laser Notice No. 50, dated (June 24, 2007).

### Ordering Information

Ordering P/Ns	Description
DH88bb-SLCA	SFP28 SR, 850nm, 25.78125G, commercial temperature

**Contact Us**

**International Sales**

Email: [Sales@broadex-tech.co.uk](mailto:Sales@broadex-tech.co.uk)

Tel: +44-1506-426021

Mobile: +44-7968-854124

**China Sales**

Tel: +86-573-82585881

Email: [Sales@broadex-tech.com](mailto:Sales@broadex-tech.com)

**Copyright © 2020 Broadex Technologies. All rights reserved**