

25GBASE-LR SFP28 Optical Transceiver

Product Features

- Compliant to the IEEE802.3cc, SFF-8472, SFF-8431 and SFF-8432
- Support 9.8304Gbps、10.1376Gbps、10.3125Gbps、24.33024Gbps、25.78125Gbps for 25G Ethernet, CPRI and eCPRI application
- 25Gbps NRZ electric interface and 25Gbps NRZ optical interface.
- Duplex LC Connector Interface, Hot Pluggable
- Built-in digital diagnostic functions through 0~400kHz clock frequency I2C bus
- 2m~10km link length over G.652 fiber
- 1310nm DFB transmitter and PIN receiver
- Single +3.3V power supply, and maximum power dissipation 1W Operation case temperature -40~85°C for industrial application
- RoHS compliance, and Class 1 laser safety

Absolute Maximum Ratings

Parameter	Unit	Min.	Typical	Max.	Notes
Storage Temperature	°C	-40		85	
Operating Case Temperature	°C	-40		85	note1
Operating Relative Humidity	%			85	
Power Supply not Damaged Voltage	V	-0.5		3.63	
Power Supply Working Voltage	V	3.135	3.3	3.465	
Power Consumption	W			1.1	
sustained peak Current	mA			400	
Instantaneous peak current	mA			450	
Bit Rate	Gbps	9.8304	25.78	25.78125	note2
Damaged Input Optical Power	dBm	3			

Notes: 1. Case Temperature here is depending on module case around TOSA, please do remember it is NOT the environment temperature. 2. The Bit Rate should support 9.8304Gbps、10.1376Gbps、10.3125Gbps、24.33024Gbps、25.78125Gbps

Characteristics

All performance is specified at whole working temperature and conditions

Parameter	Unit	Min.	Typical	Max.
Transmitter				
TX Central Wavelength	nm	1295	1310	1325
Spectral Width (-20dB)	nm			1
Side-Mode Suppression Ratio	dB	30		
Launch Optical Power (EOL)	dBm	-7		2
Optical Modulation Amplitude (EOL)	dBm	-4		2.2
Launch Optical Power when TxDisabled	dBm			-30
Extinction Ratio	dB	3.5		
Optical Return Loss Tolerance	dB			20
Transmitter and Dispersion Penalty	dB			2.7
Transmitter Mask (PRBS2 ³¹ -1@9.8304Gb/s~10.3125Gb/s, 500-waveform, HitRatio<1E-12)	Compliant With IEEE Std 802.3ae Mask Margin >5%			
Transmitter Mask (PRBS2 ³¹ -1@24.33024Gb/s~25.78125Gb/s, 500-waveform, HitRatio<5E-5)	Compliant With IEEE Std 802.3cc Mask Margin >5%			
Receiver				
RX Central Wavelength	nm	1295	1310	1325
OMA Sensitivity @BER<5E-5, PRBS2 ³¹ -1, ER>3.5dB, 24.33024G~25.78125G @BER<1E-12, PRBS2 ³¹ -1, ER>3.5dB, 9.8304G ~10.3125G	dBm			-11.3
Saturation Input Optical Power	dBm	2.0		
Optical Return Loss	dB			-26
LOS De-assert	dBm			-16
LOS Assert	dBm	-30		
LOS Hysteresis	dB	0.5		
Receiver reflectance	dBm			-26
Receiver Output Emphasis	dB		1	2
LOS Squelch function		enable		
LOS Criterion		Optical Average Power		
Electrical				
Data Input Swing Differential of 25G	mV	50	-	900
Data Input Swing Differential of 10G	mV	190	-	1200
Data Differential Impedance	Ω	90	100	110
Data Output Swing Differential I of 25G	mV	450		750
Data Output Swing Differential I of 10G	mV	450		750
Data Differential Impedance	Ω	90	100	110
LVTTL Output High	V	2		Vcc
LVTTL Output Low	V	0		0.4
LVTTL Input High	V	2.0		Vcc+0.3
LVTTL Input Low	V	-0.3		0.8

Note: The Receiver Output Emphasis Default setting=1dB

PIN Function Definitions

Pin No.	Symbol	Level / Logic	Description
1	VeeT		Module Transmitter Ground
2	Tx_Fault	LVTTL-O	Module Transmitter Fault Indication
3	Tx_DIS	LVTTL-I	Transmitter Disable; Active High Disable Transmitter Output
4	SDA	LVTTL-I	2-Wire Serial Interface Data Line
5	SCL	LVTTL-I/O	2-Wire Serial Interface Clock
6	MOD_ABS	LVTTL-O	Module Absent, connected to ground in the module
7	RS0		Rate Select 0, optionally controls SFP28 module receiver
8	RX_LOS	LVTTL-O	Loss of Receiver Signal Indication
9	RS1		Rate Select 1, optionally controls SFP28 module transmitter
10	VeeR		Module Receiver Ground
11	VeeR		Module Receiver Ground
12	RD-	CML-O	Receiver Inverted Data Output
13	RD+	CML-O	Receiver Non-Inverted Data Output
14	VeeR		Module Receiver Ground
15	VccR		Module Receiver 3.3V Supply
16	VccT		Module Transmitter 3.3V Supply
17	VeeT		Module Transmitter Ground
18	TD+	CML-I	Transmitter Non-Inverted Data Input
19	TD-	CML-I	Transmitter Inverted Data Input
20	VeeT		Module Transmitter Ground

Typical Interface Circuit

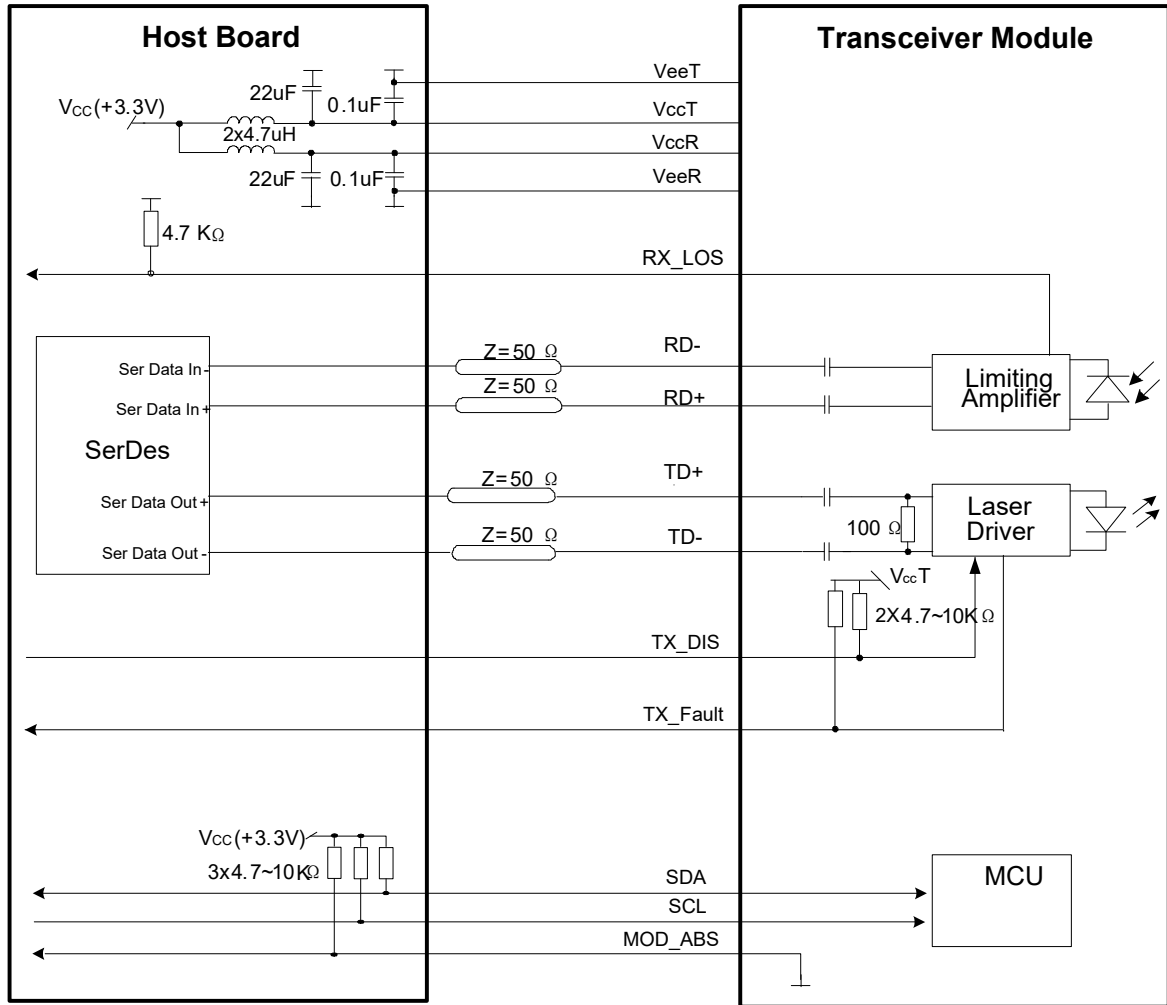

SFP28 Transceiver Electrical Pad Layout

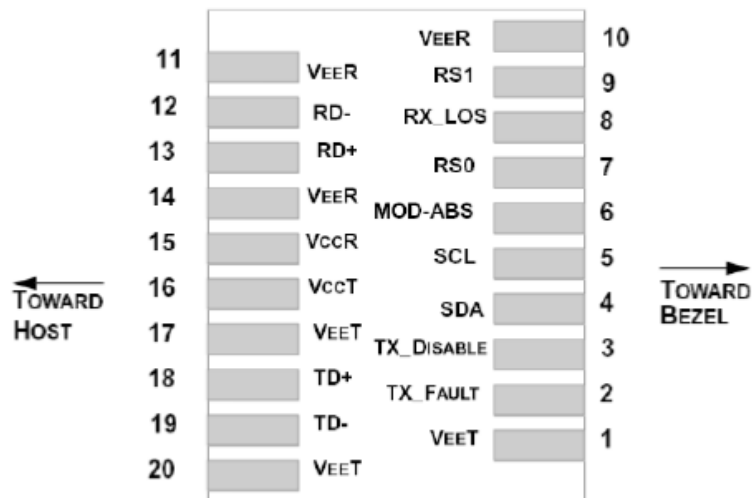

Mechanical Specifications

For detail mechanical information, please refer to the related document of SFF-8432.

Unit:mm

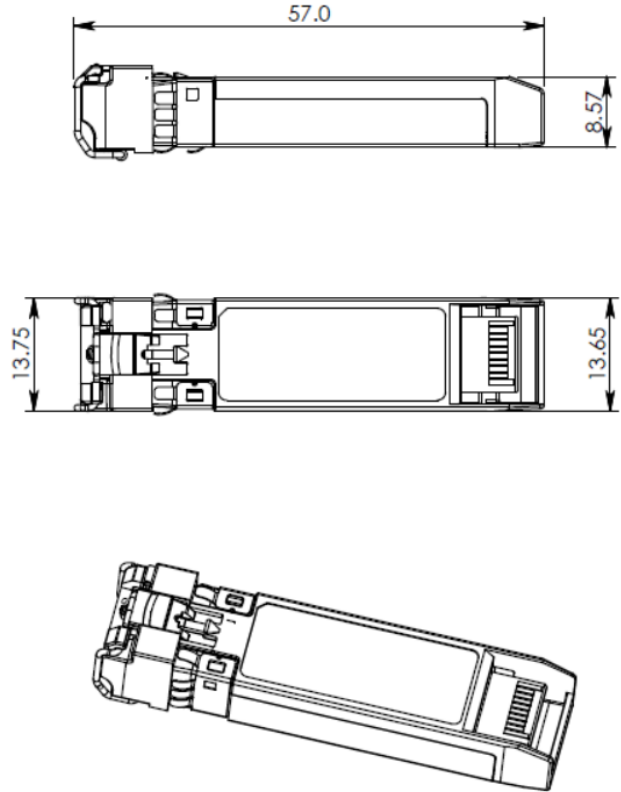

EEPROM Information

The digital diagnostic memory map specific data field define as following. For detail EEPROM information, please refer to the related document of SFF 8472 Rev 12.0.

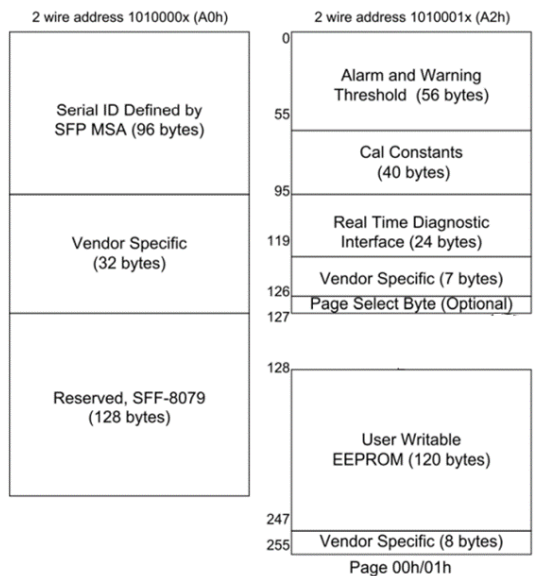

EEPROM A0h Definitions

Data	Size	Name of Field	Description	Hex Value
Address	(Bytes)			
0	1	Identifier	SFP/SFP+/SFP28	03
1	1	Ext.Identifier	Serial ID module	04
2	1	Connector	LC Connector	07
3-10	8	Transceiver	Unspecified	00 00 00 00 00 00 00 00
11	1	Encoding	NRZ	03
12	1	BR, Nominal	>25Gbps	FF
13	1	Rate Identifier	Unspecified	0D
14	1	Length(SMF, km)	10km	0A
15	1	Length(SMF)	10km	64
16	1	Length(50um)	not support	00
17	1	Length(62.5um)	not support	00
18	1	Length(Copper)	not support	00
19	1	Length(OM3)	not support	00
20-35	16	Vendor name	SFP vendor name (ASCII)	XXX
36	1	Transceiver	25G Base LR	03
37-39	3	Vendor OUI	SFP vendor IEEE company ID	XXX
40-55	16	Vendor PN	Part number	XXX
56-59	4	Vendor rev	Revision level for part number	"x.X"
60-61	2	Wavelength	1310nm	05 1E
62	1	Unallocated	Unspecified	00
63	1	CC_BASE	Check code (0 to 62)	XX
64	2	Options	Page selection,CDR	00
65			RATE_SELECT, TxDisable, TxFault ,RX_LOS functions implemented	3A
66	1	BR, max	Upper bit rate margin, units of %	67
67	1	BR, min	Lower bit rate margin, units of %	00
68-83	16	Vender SN	Serial number provided by vendor	XXX
84-91	8	Date code	Vendor's manufacturing date code	XXX
92	1	Diagnostic	Internal cal , Average Power	68
93	1	Enhanced Options	Optional Alarm/warning implemented. Soft TX_DIS,TX_FAULT,RX_LOS,RATE_SELECT implemented	F8
94	1	SFF-8472 Compliance	Diagnostics Compliance(SFF-8472 V12.0)	08
95	1	CC_EXT	Check code (64 to 94)	XX

EEPROM A2 Alarm and Warning Threshold

Data	Name of Field	Hex Value	Description
Address			
0	Temperature High alarm threshold	64	100 °C
1		00	
2	Temperature Low alarm threshold	CE	-50 °C
3		00	
4	Temperature High warning threshold	5A	90 °C
5		00	
6	Temperature Low warning threshold	D8	-40 °C
7		00	
8	Voltage High alarm threshold	8D	3.63 V
9		CC	
10	Voltage Low alarm threshold	74	2.97 V
11		04	
12	Voltage High warning threshold	87	3.465 V
13		5A	
14	Voltage Low warning threshold	7A	3.135 V
15		75	
16	Bias High alarm threshold	C3	100 mA
17		50	
18	Bias Low alarm threshold	13	10mA
19		88	
20	Bias High warning threshold	9C	80 mA
21		40	
22	Bias Low warning threshold	27	20 mA
23		10	
24	TX power High alarm threshold	7B	5dBm
25		87	
26	TX power Low alarm threshold	03	-10 dBm
27		E8	
28	TX power High warning threshold	3D	2 dBm
29		E9	
30	TX power Low warning threshold	07	-7dBm
31		CB	
32	RX power High alarm threshold	7B	5 dBm
33		87	
34	RX power Low alarm threshold	00	-16.3 dBm
35		EA	
36	RX power High warning threshold	3D	2 dBm

37		E9	
38	RX power Low warning threshold	01	-13.3dBm
39		D4	

Rate selection

The period of rate selection ≤100ms (From the module receives the rate selection configuration to Completes the rate selection).

Logic OR of RS0 pin and RS0 bit	Logic OR of RS1 pin and RS1 bit	Receiver retimer/CDR	Transmitter retimer/CDR	Rate
Low/0	Low/0	CDR Bypass	CDR Bypass	Tx and Rx: 9.8304Gbps, 10.1376Gbps or 10.3125Gbps
Low/0	High/1	CDR Bypass	CDR Lock at High Data Rate	Tx: 24.33024Gbps or 25.78125Gbps. Rx: 9.8304Gbps, 10.1376Gbps or 10.3125Gbps
High/1	Low/0	CDR Lock at High Data Rate	CDR Bypass	Tx: 9.8304Gbps, 10.1376Gbps or 10.3125Gbps Rx: 24.33024Gbps or 25.78125Gbps.
High/1	High/1	CDR Lock at High Data Rate	CDR Lock at High Data Rate	Tx and Rx(Default value): 24.33024Gbps or 25.78125Gbps.

Note: The period of rate selection ≤100ms (From the module receives the rate selection configuration to Completes the rate selection).

DDMI Range and LSB Definition (0xA2)

Parameter	Range	Error	NOTES
Temperature	-50 to 100°C	±3°C	1LSB=1/256°C
Vcc Voltage	3V to 4 V	±0.1V	1LSB=0.1mV
TX Bias Current	10 to 100mA	10%	1LSB=2uA
TX Power	-6to 2dBm	±3dB	1LSB=0.1uW
RX Power	-16.4 to 2.5dBm	±3dB	1LSB=0.1uW

ESD

The SFP+ module and host SFI contacts (High Speed Contacts) shall withstand 1kV electrostatic discharge based on Human Body Model and all host contacts with exception of the SFI contacts (High Speed Contacts) shall withstand 2kV electrostatic discharge based on Human Body Model. The SFP+ module shall meet ESD requirements given in EN61000-4-2, criterion B test specification such that units are subjected to 15kV air discharges during operation and 8kV direct contact discharges to the case per section 2.9 in SFF-8431 REV4.1. However, normal ESD precautions are still required during the handling of this module. This transceiver is shipped in ESD protective packaging. It should be removed from the packaging and handled only in an ESD protected environment.

Laser Safety

This is a Class 1 Laser Product according to IEC 60825-1:2007. This product complies with 21 CFR 1040.10 and 1040.11 except for deviations pursuant to Laser Notice No. 50, dated (June 24, 2007).

Ordering Information

Ordering P/Ns	Description
D133bb-SLHB	10~25G 10km SFP28 NRZ-NRZ, Tx 1310nm, Rx 1310nm, SFP28 form-factor, Duplex LC receptacle connector, -40~85°C Industrial temperature, SiPH technology based

Contact Us**TAIHEI BOEKI CO., LTD.**

光学機器課

〒103-0023 東京都中央区日本橋本町2-2-2

TEL 03-3270-4826 FAX 03-3245-1767

<http://www.taiheiboeki.co.jp>tokyo@taiheiboeki.co.jp**Copyright © 2020 Broadex Technologies. All rights reserved**