

25G 20km LWDM SFP28 Optical Transceiver

Product Features

- Support 25GE and eCPRI, with data rate up to 25.78125Gbps
- 18dB link budget, up to 20km transmission distance over SMF
- LWDM 1286.6629nm, 1291.0959nm, 1295.5595, 1300.0540, 1304.5799, 1309.1374nm transmitter with cooled laser
- 1260~1620nm receiver with APD-TIA
- 2-wire interface for integrated digital diagnostic Monitoring
- SFP28 package with duplex LC/UPC receptacle optical interface and SFI electrical interface
- Single +3.3V power supply
- Operation case temperature -40~85°C for Industrial
- RoHS compliance, and Class 1 laser safety

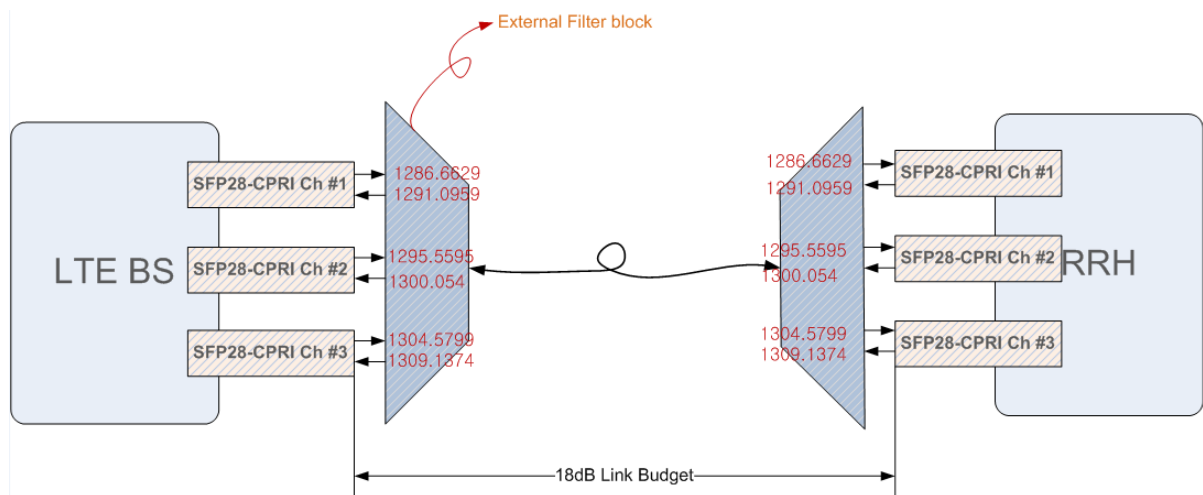

Operating Conditions

Parameter	Unit	Min.	Typical	Max.
Storage Temperature	°C	-40		85
Operating Case Temp	°C	-40		85
Power Supply Voltage	V	3.135	3.3	3.465
Power Dissipation	W			2
Bit Rate	Gbps		25.78	

Characteristics

All performance is specified at whole working temperature and conditions

Parameter	Unit	Min.	Typical	Max.
Transmitter				
TX Central Wavelength (D1)	nm	1285.648	1286.663	1287.68
TX Central Wavelength (R1)	nm	1290.074	1291.096	1292.12
TX Central Wavelength (D2)	nm	1294.53	1295.560	1296.59
TX Central Wavelength (R2)	nm	1299.018	1300.054	1301.092
TX Central Wavelength (D3)	nm	1303.536	1304.580	1305.625
TX Central Wavelength (R3)	nm	1308.086	1309.137	1310.19
Spectral Width (-20dB)	nm			1
Side Mode Suppression Ratio (SMSR)	dB	30		
Mean Launched Power	dBm	2		6
Mean Launched Power (TX Off)	dBm			-45
Extinction Ratio	dB	3.5		
Optical Return Loss Tolerance	dB	-12		
Transmitter and dispersion Penalty	dB			3.2
Transmitter Mask (PRBS2 ³¹ -1@25.78G)	Compliant With IEEE Std P802.3by			
Receiver				
RX Central Wavelength (D1)	nm	1290.074	1291.096	1292.12
RX Central Wavelength (R1)	nm	1285.648	1286.663	1287.68
RX Central Wavelength (D2)	nm	1299.018	1300.054	1301.092
RX Central Wavelength (R2)	nm	1294.53	1295.560	1296.59
RX Central Wavelength (D3)	nm	1308.086	1309.137	1310.19
RX Central Wavelength (R3)	nm	1303.536	1304.580	1305.625
Sensitivity @BER less than 1E-12 with PRBS2 ³¹ -1,ER=4dB at 25.78G	dBm			-16
Overload @BER less than 1E-12 with PRBS2 ³¹ -1,ER=4dB at 25.78G	dBm	-4		
LOS De-assert Level	dBm			-16
LOS Assert Level	dBm	-30		
LOS Hysteresis	dB	0.5		
Electrical Interface Characteristics				
Data Input Swing Differential/TX	mV	200	-	900
Data Output Swing Differential/RX	mV	300		1000
Data Differential Impedance	Ω	90	100	110
LVTTTL Output High	V	2.4		V _{cc}
LVTTTL Output Low	V	0		0.4
LVTTTL Input High	V	2.0		V _{cc} +0.3
LVTTTL Input Low	V	0		0.8
Timing Characteristics				
LOS Assert Time (T _{LOSA})	us			100
LOS De-assert Time (T _{LOSD})	us			100

PIN Definition

Pin No.	Symbol	Level / Logic	Description
1	VeeT		Module Transmitter Ground
2	Tx_Fault	LVTTL-O	Module Transmitter Fault Indication
3	Tx_DIS	LVTTL-I	Transmitter Disable; Active High Disable Transmitter Output
4	SDA	LVTTL-I	2-Wire Serial Interface Data Line
5	SCL	LVTTL-I/O	2-Wire Serial Interface Clock
6	MOD_ABS	LVTTL-O	Module Absent, connected to ground in the module
7	RS0		Not Connected
8	RX_LOS	LVTTL-O	Loss of Receiver Signal Indication
9	RS1		Not Connected
10	VeeR		Module Receiver Ground
11	VeeR		Module Receiver Ground
12	RD-	CML-O	Receiver Inverted Data Output
13	RD+	CML-O	Receiver Non-Inverted Data Output
14	VeeR		Module Receiver Ground
15	VccR		Module Receiver 3.3V Supply
16	VccT		Module Transmitter 3.3V Supply
17	VeeT		Module Transmitter Ground
18	TD+	CML-I	Transmitter Non-Inverted Data Input
19	TD-	CML-I	Transmitter Inverted Data Input
20	VeeT		Module Transmitter Ground

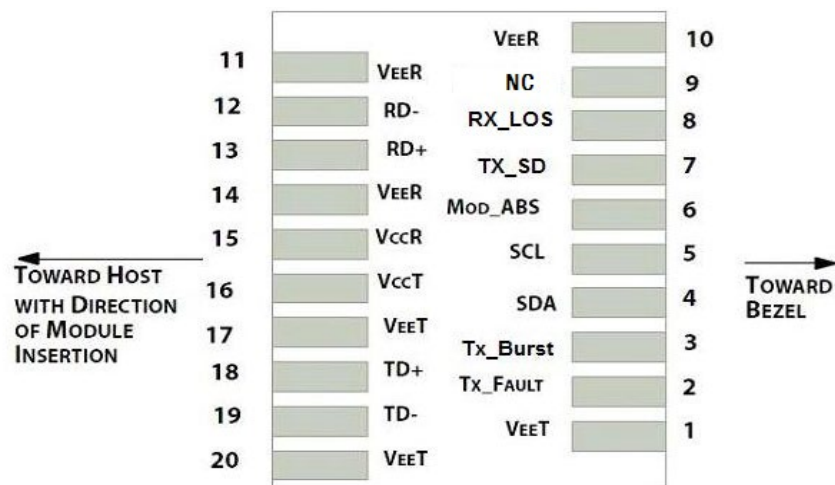

Typical Interface Circuit

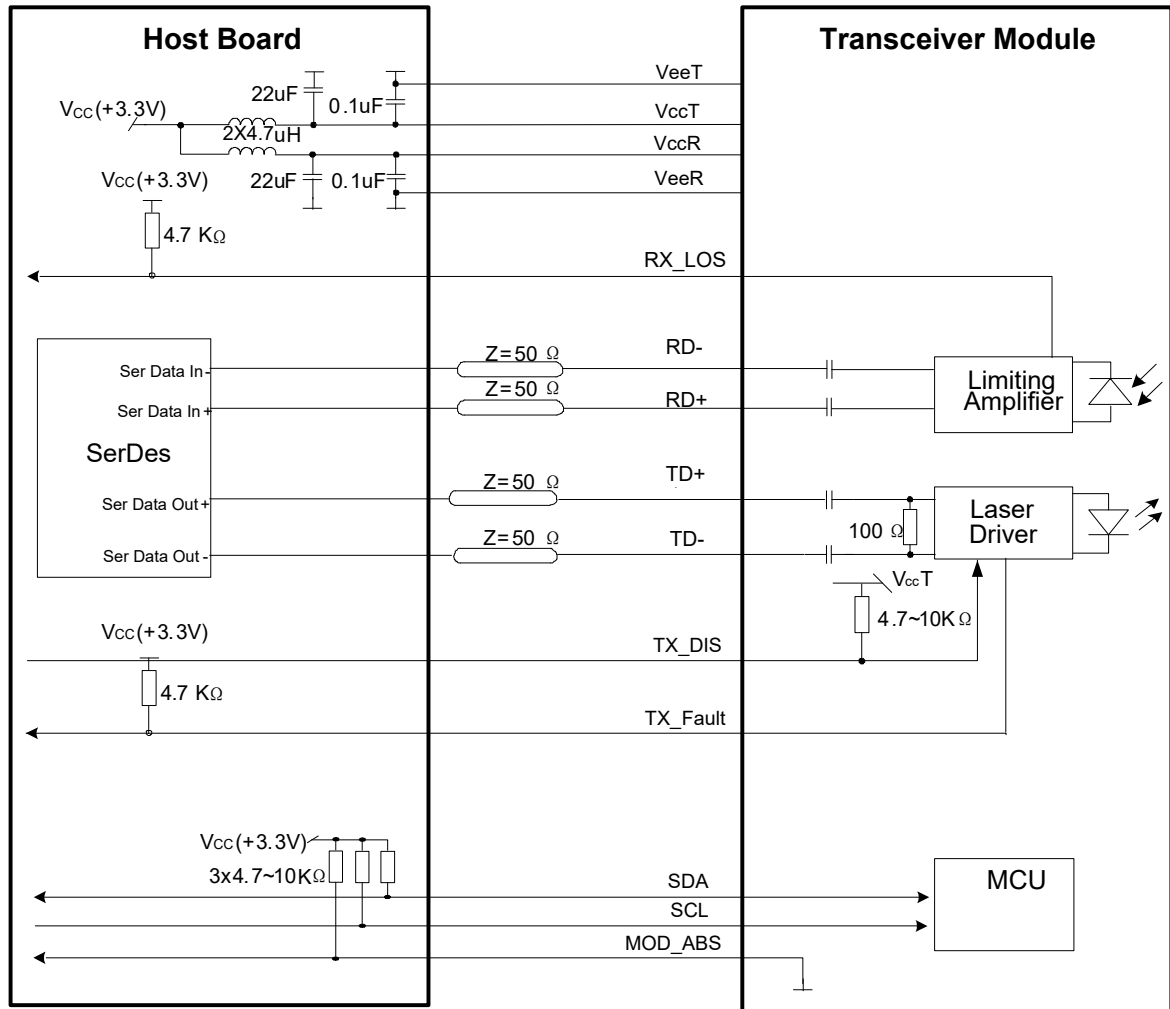

Mechanical Diagram

For detail mechanical information, please refer to the related document of SFF-8432

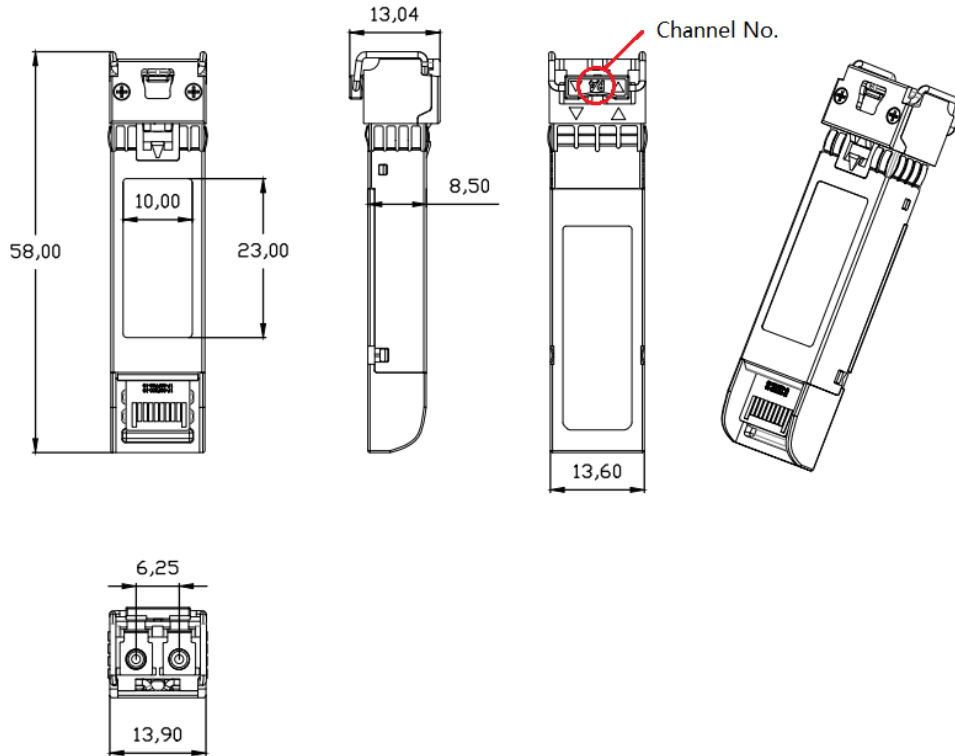

EEPROM Memory Map

The digital diagnostic memory map specific data field define as following. For detail EEPROM information, please refer to the related document of SFF 8472 Rev 12.0.

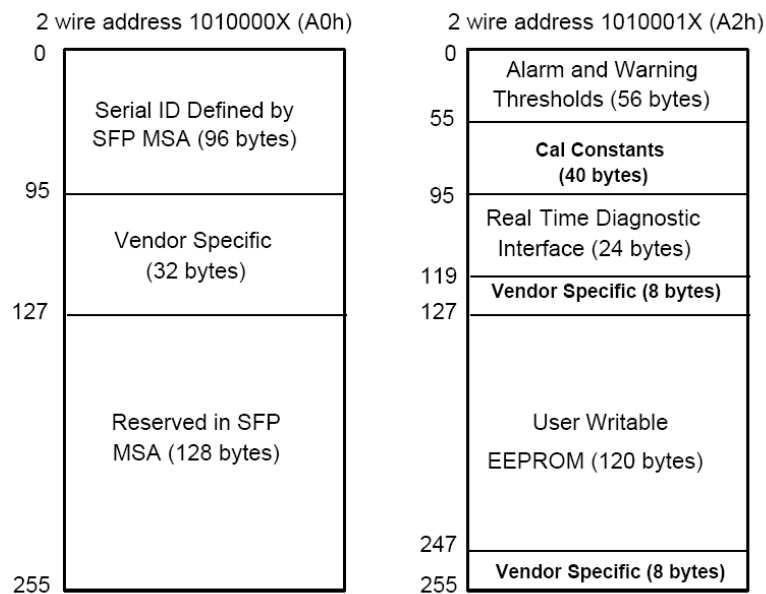

ESD

The SFP+ module and host SFI contacts (High Speed Contacts) shall withstand 1kV electrostatic discharge based on Human Body Model and all host contacts with exception of the SFI contacts (High Speed Contacts) shall withstand 2kV electrostatic discharge based on Human Body Model. The SFP+ module shall meet ESD requirements given in EN61000-4-2, criterion B test specification such that units are subjected to 15kV air discharges during operation and 8kV direct contact discharges to the case per section 2.9 in SFF-8431 REV4.1. However, normal ESD precautions are still required during the handling of this module. This transceiver is shipped in ESD protective packaging. It should be removed from the packaging and handled only in an ESD protected environment.

Laser Safety

This is a Class 1 Laser Product according to IEC 60825-1:2007. This product complies with 21 CFR 1040.10 and 1040.11 except for deviations pursuant to Laser Notice No. 50, dated (June 24, 2007).

Ordering Information

Ordering P/Ns	Description
D2TTbb-SLHA-xxx	25G 20km CPRI Option10 SFP28, Tx LWDM 1286.6629~1309.1374nm, Rx 1310nm, SFP+ form-factor, Duplex LC/UPC receptacle connector, -40~85°C Industrial temperature

Note : "xxx" in P/N is the wavelength definition.

For example: D2DD99-SLHC-286: central wavelength 1286.6629 nm

Channel No.(xxx)	P/N	Center Wavelength (nm)	Latch color
D1	D2TTbb-SLHA-286	1286.6629	Green
R1	D2TTbb-SLHA-291	1291.0959	Blue
D2	D2TTbb-SLHA-295	1295.5595	Green
R2	D2TTbb-SLHA-300	1300.0540	Blue
D3	D2TTbb-SLHA-304	1304.5799	Green
R3	D2TTbb-SLHA-309	1309.1374	Blue

Contact Us

 太平貿易株式会社

TAIHEI BOEKI CO., LTD.

光学機器課

〒103-0023 東京都中央区日本橋本町2-2-2

TEL 03-3270-4826 FAX 03-3245-1767

<http://www.taiheiboeki.co.jp>

tokyo@taiheiboeki.co.jp

Copyright © 2021 Broadex Technologies. All rights reserved