

## GPON SFP ONU Optical Transceiver

### Product Features

- Supports ITU-T 984.2, ITU-T 984.5 GPON Networks applications
- Single fiber bi-directional data links with asymmetric 1.244Gbps Tx and 2.488Gbps Rx
- 1310nm burst-mode transmitter with DFB laser
- 1490nm continuous-mode receiver with APD-TIA
- 2-wire interface for integrated digital diagnostic Monitoring
- Transmitter Burst On (optional high active or low active)
- Transmitter state indication (TX\_SD)
- Receiver state indication (optional RX\_SD or Rx\_LOS)
- SFP package with SC/UPC receptacle optical interface
- Single +3.3V power supply
- Operation case temperature -40~85°C for industrial
- RoHS compliance, and Class 1 laser safety

### Operating Conditions

Parameter	Unit	Min.	Typical	Max.
Storage Temperature	°C	-40		85
Operating Case Temp	°C	-40		85
Power Supply Voltage	V	3.135	3.3	3.465
Supply Current	mA		200	400
Bit Rate for Tx	Gbps		1.244	
Bit Rate for Rx	Gbps		2.488	

**Characteristics**

All performance is specified at whole working temperature and conditions

Parameter	Unit	Min.	Typical	Max.
<b>Transmitter</b>				
TX Central Wavelength	nm	1290	1310	1330
Spectral Width (-20dB)	nm			1
Side Mode Suppression Ratio (SMSR)	dB	30		
Mean Launched Power	dBm	0.5		5
Mean Launched Power (TX Off)	dBm			-45
Extinction Ratio	dB	10		
Optical Return Loss Tolerance	dB	-15		
Transmitter and dispersion Penalty	dB			1
Transmitter Mask (PRBS2 <sup>23</sup> -1@1.244G)	Compliant With ITU-T G984.2			
<b>Receiver</b>				
Receive Wavelength	nm	1480	1490	1500
Sensitivity (PRBS2 <sup>23</sup> -1@2.488G, ER=8.2, BER<10 <sup>-10</sup> )	dBm			-28
Overload (PRBS2 <sup>23</sup> -1@2.488G, ER=8.2, BER<10 <sup>-10</sup> )	dBm	-8		
LOS De-assert Level	dBm			-29
LOS Assert Level	dBm	-39		
LOS Hysteresis	dB	0.5		6
WDM Filter isolation to 1441 nm ~1450 nm, 1530 nm ~1539 nm	dB	25		
WDM Filter isolation to 1250 nm ~1441 nm, 1539 nm ~1625 nm	dB	36		
<b>Electrical Interface Characteristics</b>				
Data Input Swing Differential/TX	mV	200	-	2000
Data Output Swing Differential/RX	mV	400		1600
Data Differential Impedance	Ω	90	100	110
LVTTL Output High	V	2.4		Vcc
LVTTL Output Low	V	0		0.4
LVTTL Input High	V	2.0		Vcc+0.3
LVTTL Input Low	V	0		0.8
<b>Timing Characteristics</b>				
Turn On Time at Burst mode (T <sub>ON</sub> )	ns			12.8
Turn Off Time at Burst mode (T <sub>OFF</sub> )	ns			12.8
TX-SD Assert Time (T <sub>TXSD_ON</sub> )	ns			100

TX-SD De-assert Time ( $T_{TXSD\_OFF}$ )	ns			100
LOS Assert Time ( $T_{LOSA}$ )	us			100
LOS De-assert Time ( $T_{LOSD}$ )	us			100

**Burst Mode Transmitter Timing**

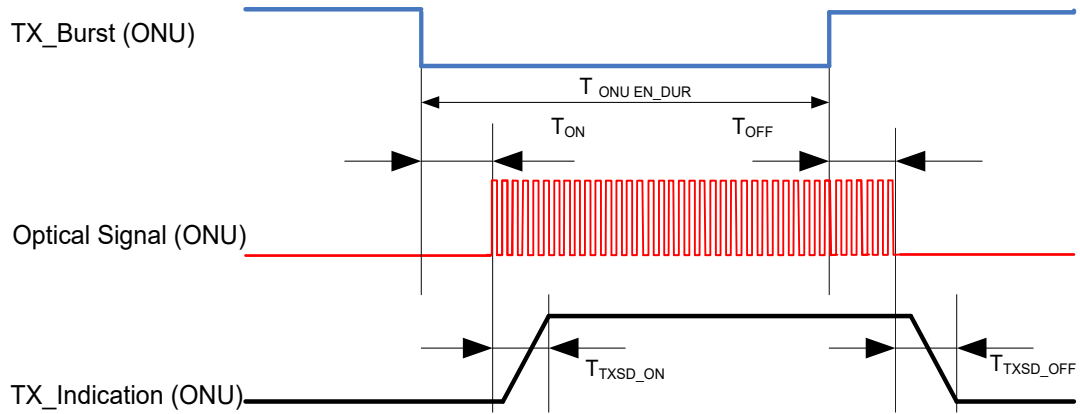

**PIN Definition**

Pin No.	Symbol	Level / Logic	Description
1	VeeT		Module Transmitter Ground
2	Tx_Fault	LVTTTL-O	Module Transmitter Fault
3	Tx_Burst	LVTTTL-I	Transmitter Burst Control, active low for transmitter on
4	SDA	LVTTTL-I	2-Wire Serial Interface Data Line
5	SCL	LVTTTL-I/O	2-Wire Serial Interface Clock
6	MOD_ABS	LVTTTL-O	Module Absent, connected to ground in the module
7	TX_SD	LVTTTL-O	Tx Signal Detect, active high when transmitter on
8	Rx_LOS or RX_SD	LVTTTL-O	Receiver Signal Indication Rx_LOS, active high when loss of input optical signal Rx_SD, active high when received input optical signal
9	NC		
10	VeeR		Module Receiver Ground
11	VeeR		Module Receiver Ground
12	RD-	CML-O	Receiver Inverted Data Output, AC-coupled
13	RD+	CML-O	Receiver Non-Inverted Data Output, AC-coupled
14	VeeR		Module Receiver Ground
15	VccR		Module Receiver 3.3V Supply
16	VccT		Module Transmitter 3.3V Supply
17	VeeT		Module Transmitter Ground
18	TD+	LVPECL-I	Transmitter Non-Inverted Data Input, DC-coupled
19	TD-	LVPECL-I	Transmitter Inverted Data Input, DC-coupled
20	VeeT		Module Transmitter Ground

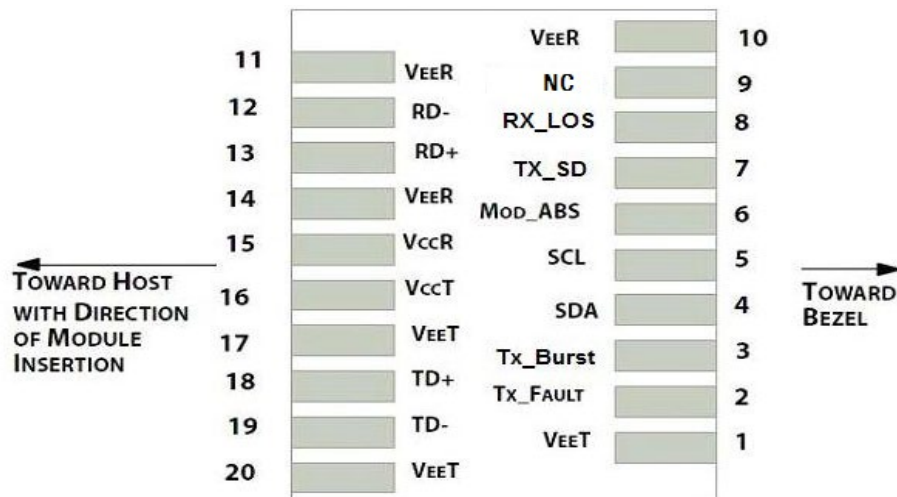

Typical Interface Circuit

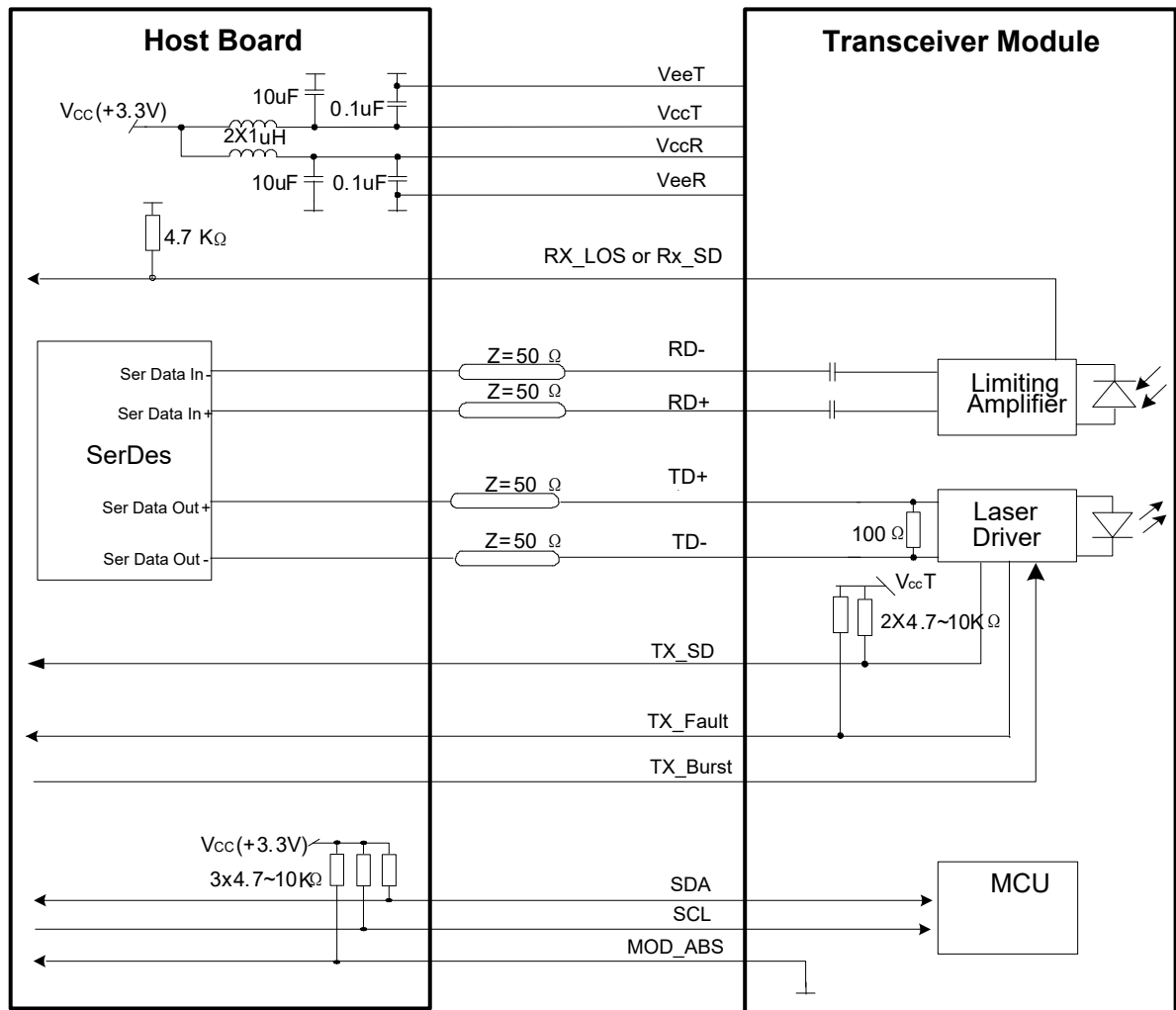

**Mechanical Diagram**

For detail mechanical information, please refer to the related document of SFP MSA

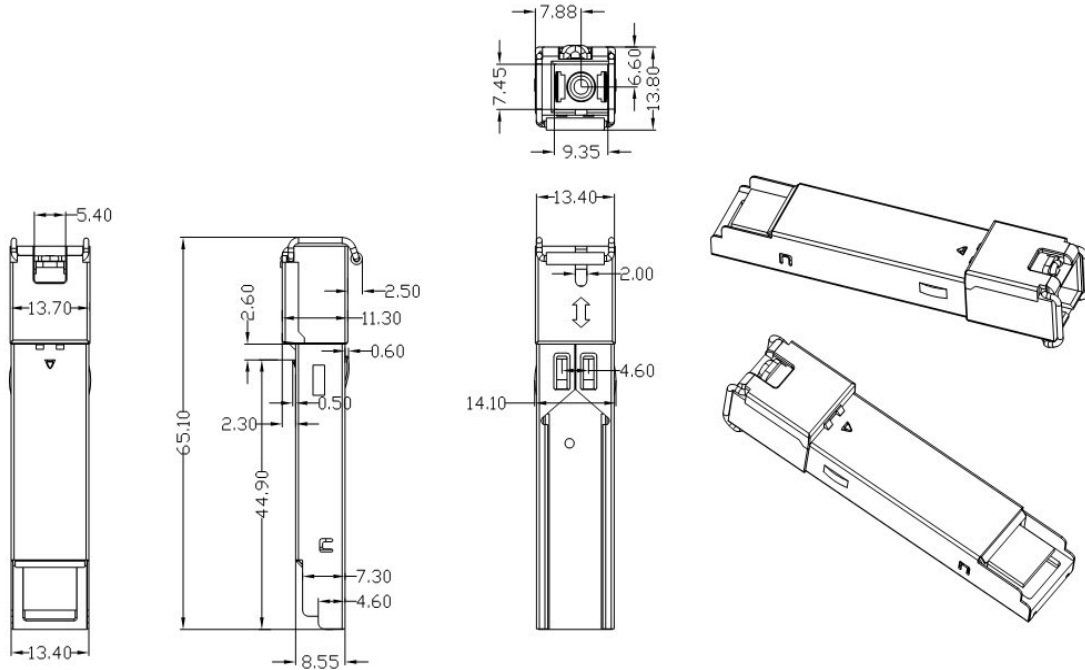

**EEPROM Memory Map**

The digital diagnostic memory map specific data field define as following. For detail EEPROM information, please refer to the related document of SFF 8472 Rev 12.0.

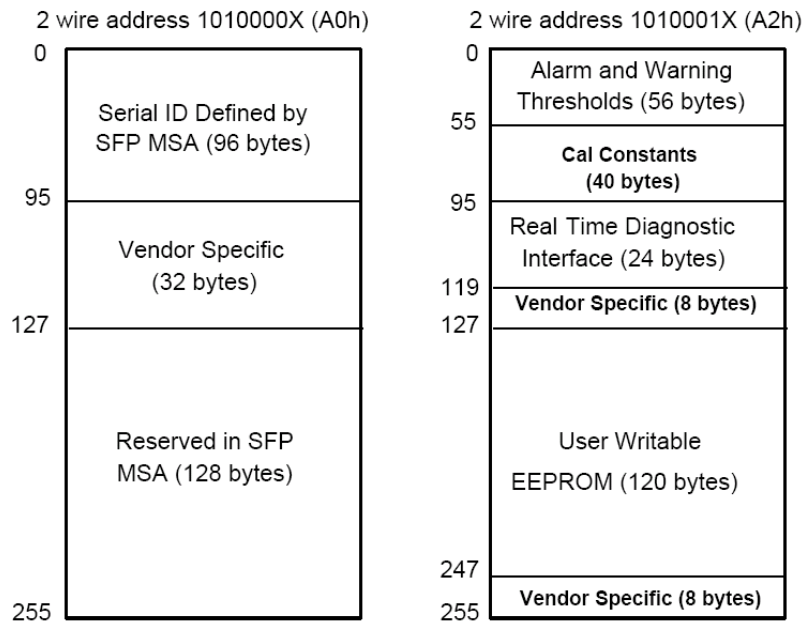

**ESD**

The SFP+ module and host SFI contacts (High Speed Contacts) shall withstand 1kV electrostatic discharge based on Human Body Model and all host contacts with exception of the SFI contacts (High Speed Contacts) shall withstand 2kV electrostatic discharge based on Human Body Model. The SFP+ module shall meet ESD requirements given in EN61000-4-2, criterion B test specification such that units are subjected to 15kV air discharges during operation and 8kV direct contact discharges to the case per section 2.9 in SFF-8431 REV4.1. However, normal ESD precautions are still required during the handling of this module. This transceiver is shipped in ESD protective packaging. It should be removed from the packaging and handled only in an ESD protected environment.

**Laser Safety**

This is a Class 1 Laser Product according to IEC 60825-1:2007. This product complies with 21 CFR 1040.10 and 1040.11 except for deviations pursuant to Laser Notice No. 50, dated (June 24, 2007).

**Ordering Information**

Ordering P/Ns	Description
D23446-SSHA	GPON SFP ONU, B+,1.244Gbps Tx 1310nm, 2.488Gbps Rx 1490nm, TX_Burst signal low active transmitter on, Rx_LOS signal high active when loss of input signal, SFP form-factor, SC/UPC receptacle connector, Industrial temperature

**Contact Us****太平貿易株式会社****TAIHEI BOEKI CO., LTD.**

光学機器課

〒103-0023 東京都中央区日本橋本町2-2-2

TEL 03-3270-4826 FAX 03-3245-1767

<http://www.taiheiboeki.co.jp>[tokyo@taiheiboeki.co.jp](mailto:tokyo@taiheiboeki.co.jp)**Copyright © 2021 Broadex Technologies. All rights reserved**