

100G QSFP28 to 4x25G SFP28

Active Optical Cable

Product Features

- Compliant to QSFP28 MSA SFF-8636
- Compliant to SFP28 MSA SFF-8431 and SF-8472
- 850nm VCSEL Transmitter
- PIN photo-detector receiver
- +3.3V single power supply
- Low power consumption
- Length up to 70m using OM3 MMF and 100m using OM4 MMF
- Operating case temperature range 0°C to +70 °C
- RoHS compliant

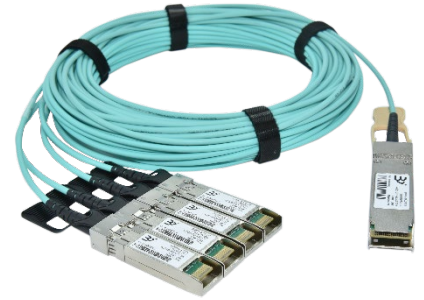

Applications

- 4x25GBASE-SR
- Servers, switches, storage and host card adapters

Absolute Maximum Ratings

Parameter	Unit	Min.	Typical	Max.	Notes
Storage Temperature	°C	-40		85	
Operating Relative Humidity	%	5		85	
Power Supply not Damaged Voltage	V	-0.5		3.6	

Recommended Operating Conditions

Parameter	Unit	Min.	Typical	Max.	Notes
Operating Case Temperature	°C	0	20	70	
Power Supply Working Voltage	V	3.135	3.3	3.145	
QSFP28 Power Dissipation	W	-	-	2.5	
SFP28 Power Dissipation per terminal	W	-	-	1	
Bit Rate per Channel	Gbps	10.3215	25.78125		
Bit Error Rate				1x10 ⁻¹²	

Electrical Specifications

Parameter		Symbol	Min.	Typ.	Max.	Units	Notes
ModSelL	Module Select	V_{OL}	0	-	0.8	V	
	Module Unselect	V_{OH}	2.5	-	V_{CC}	V	
LPMode	Low Power Mode	V_{IL}	0	-	0.8	V	
	Normal Operation	V_{IH}	2.5	-	$V_{CC}+0.3$	V	
ResetL	Reset	V_{IL}	0	-	0.8	V	
	Normal Operation	V_{IH}	2.5	-	$V_{CC}+0.3$	V	
ModPrsL	Normal Operation	V_{OL}	0	-	0.4	V	
IntL	Interrupt	V_{OL}	0	-	0.4	V	
	Normal Operation	V_{OH}	2.4	-	V_{CC}	V	
Transmitter							
Differential Data Input Swing		V_{out}	200	-	1600	mV	
Output Differential Impedance		Z_D	90	100	110	Ω	
Receiver							
Differential Data Output Swing		$V_{in,P-P}$	200	-	800	mV _{PP}	
Input Differential Impedance		Z_{IN}	90	100	110	Ω	

Note:

1. PRBS2^31-1@25.78125Gbps

PIN Function Definitions for QSFP28

Pin No.	Symbol	Level / Logic	Description	Notes
1	GND		Module Ground	1
2	Tx2n	CML-I	Transmitter Inverted Data Input	
3	Tx2p	CML-I	Transmitter Non-Inverted Data Input	
4	GND		Module Ground	1
5	Tx4n	CML-I	Transmitter Inverted Data Input	
6	Tx4p	CML-I	Transmitter Non-Inverted Data Input	
7	GND		Module Ground	1
8	ModSelL	LVTTTL-I	Module Select	
9	ResetL	LVTTTL-I	Module Reset	
10	VccRx		+3.3V Power Supply for Receiver	2
11	SCL	LVTTTL-I	2-Wire Serial Interface Clock	
12	SDA	LVTTTL-I/O	2-Wire Serial Interface Data Line	
13	GND		Module Ground	1
14	Rx3p	CML-O	Receiver Non-Inverted Data Output	
15	Rx3n	CML-O	Receiver Inverted Data Output	
16	GND		Module Ground	1
17	Rx1p	CML-O	Receiver Non-Inverted Data Output	
18	Rx1n	CML-O	Receiver Inverted Data Output	
19	GND		Module Ground	1
20	GND		Module Ground	1
21	Rx2n	CML-O	Receiver Inverted Data Output	
22	Rx2p	CML-O	Receiver Non-Inverted Data Output	
23	GND		Module Ground	1
24	Rx4n	CML-O	Receiver Inverted Data Output	
25	Rx4p	CML-O	Receiver Non-Inverted Data Output	
26	GND		Module Ground	1
27	ModPrsL	LVTTTL-O	Module Present	
28	IntL	LVTTTL-O	Interrupt	
29	VccTx		+3.3V Power Supply for Transmitter	2
30	Vcc1		+3.3V Power Supply	2
31	LPMODE	LVTTTL-I	Low Power Mode	
32	GND		Module Ground	1
33	Tx3p	CML-I	Transmitter Non-Inverted Data Input	
34	Tx3n	CML-I	Transmitter Inverted Data Input	
35	GND		Module Ground	1
36	Tx1p	CML-I	Transmitter Non-Inverted Data Input	
37	Tx1n	CML-I	Transmitter Inverted Data Input	
38	GND		Module Ground	1

Notes:

- 1GND is the symbol for signal and supply (power) common for the QSFP28 module. All are common within the QSFP28 module and all module voltages are referenced to this potential unless otherwise noted. Connect these directly to the host board signal-common ground plane.
- 2Vcc Rx, Vcc1 and Vcc Tx are the receiver and transmitter power supplies and shall be applied concurrently. Vcc Rx, Vcc1 and Vcc Tx may be internally connected within the QSFP28 Module in any combination.

Electrical Pad Layout for QSFP28

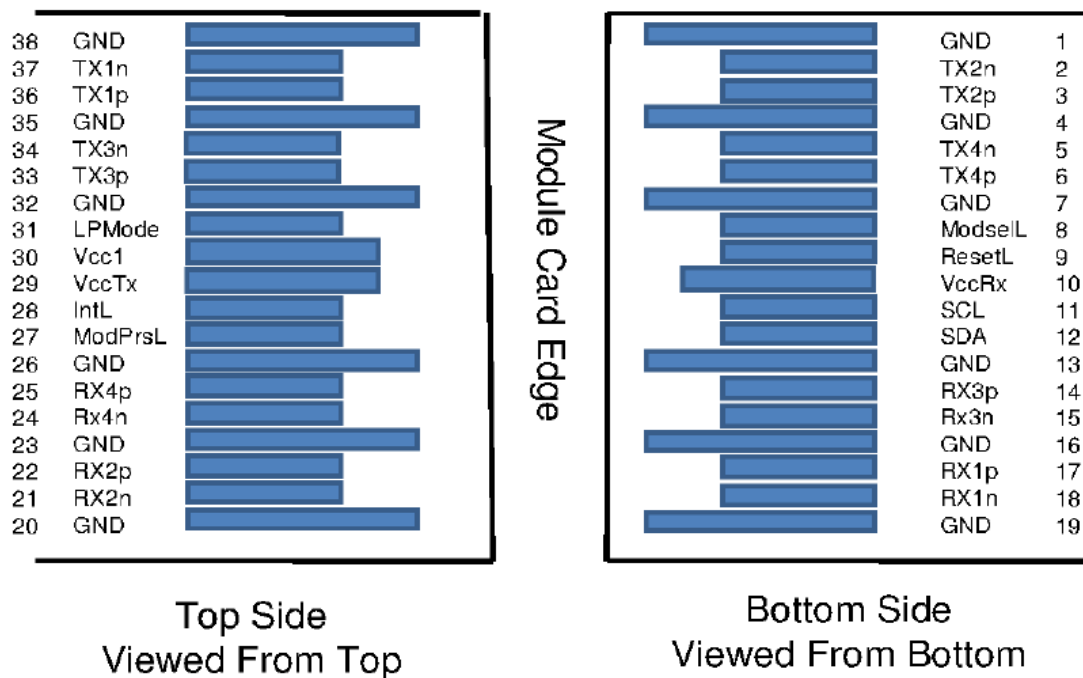

Pin Function Definitions for SFP28

Pin No.	Symbol	Level / Logic	Description	Notes
1	VeeT		Module Transmitter Ground	1
2	Tx_Fault	LVTTTL-O	Module Transmitter Fault Indication	2
3	Tx_DIS	LVTTTL-I	Transmitter Disable; Active High Disable Transmitter Output	3
4	SDA	LVTTTL-I	2-Wire Serial Interface Data Line	
5	SCL	LVTTTL-I/O	2-Wire Serial Interface Clock	
6	MOD_ABS	LVTTTL-O	Module Absent, connected to ground in the module	2
7	RS0		Rate Select 0, optionally controls SFP28 module receiver	
8	RX_LOS	LVTTTL-O	Loss of Receiver Signal Indication	2
9	RS1		Rate Select 1, optionally controls SFP28 module transmitter	
10	VeeR		Module Receiver Ground	1
11	VeeR		Module Receiver Ground	1
12	RD-	CML-O	Receiver Inverted Data Output	
13	RD+	CML-O	Receiver Non-Inverted Data Output	
14	VeeR		Module Receiver Ground	1
15	VccR		Module Receiver 3.3V Supply	
16	VccT		Module Transmitter 3.3V Supply	
17	VeeT		Module Transmitter Ground	1
18	TD+	CML-I	Transmitter Non-Inverted Data Input	
19	TD-	CML-I	Transmitter Inverted Data Input	
20	VeeT		Module Transmitter Ground	1

Note:

1. The module ground pins are isolated from the module case.
2. The pins shall be pulled up with 4.7K-10Kohms to a voltage between 3.14V and 3.46V on host board.
3. The pin is pulled up to VCCT with a 4.7K-10KΩ resistor in the module.

Electrical Pad Layout for SFP28

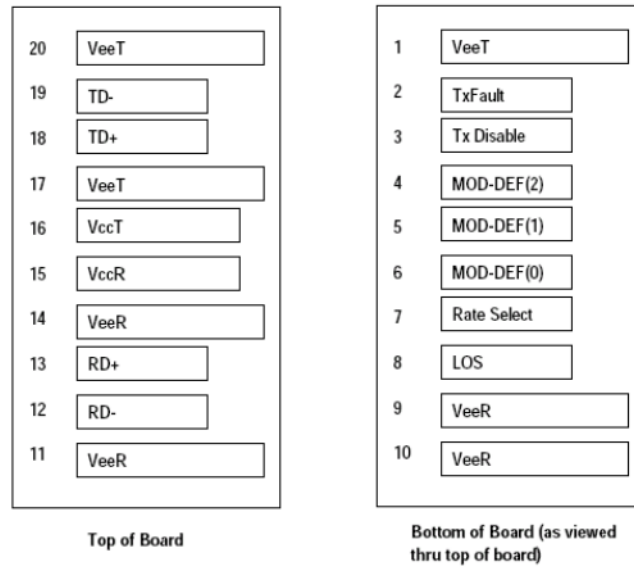

Mechanical Specifications

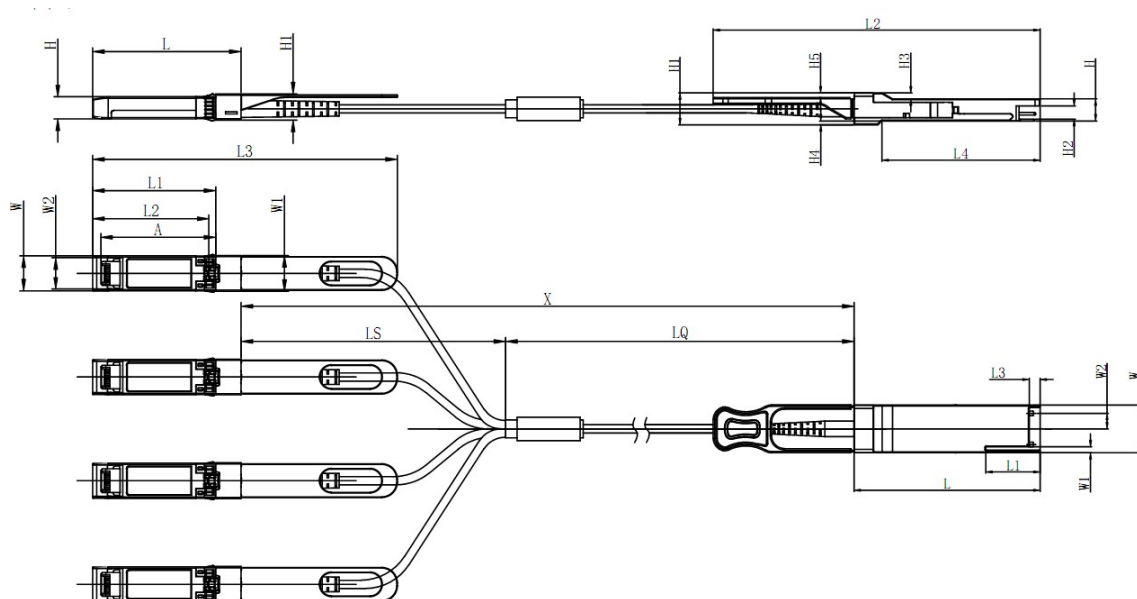

Unit mm

QSFP28	L	L1	L2	L3	L4	W	W1	W2	H	H1	H2	H3	H4	H5	H6
Max	72.2	-	128	4.35	61.4	18.45	-	6.2	8.6	12.4	5.35	2.5	1.6	2.0	-
Type	72.0	-	-	4.20	61.2	18.35	-	-	8.5	12.2	5.2	2.3	1.5	1.8	6.55
Min	68.8	16.5	124	4.05	61.0	18.25	2.2	5.8	8.4	12.0	5.05	2.1	1.3	1.6	-

SFP28	L	L1	L2	L3	W	W1	W2	H	H1	A
Max	57.6	47.7	44.55	119.9	13.8	14.0	12.3	8.7	10.3	45.25
Type	57.4	47.5	44.35	117.9	13.55	13.8	12.1	8.5	10.1	45
Min	57.2	47.3	44.15	115.9	13.3	13.6	11.9	8.4	9.9	44.65

ESD

This product is specified as ESD threshold 1kV for high speed data pins and 2kV for all other electrical input pins, tested per MIL-STD-883, Method 3015.4 /JESD22-A114-A (HBM). However, normal ESD precautions are still required during the handling of this module. This transceiver is shipped in ESD protective packaging. It should be removed from the packaging and handled only in an ESD protected environment.

Laser Safety

This is a Class 1 Laser Product according to IEC 60825-1:2007. This product complies with 21 CFR 1040.10 and 1040.11 except for deviations pursuant to Laser Notice No. 50, dated (June 24, 2007).

Ordering Information

Ordering P/Ns	Description
DH88hh-QCCC-xxx	up to 100m, 850nm, 4*25G NRZ QSFP28 break to 4*25G SFP28 AOC

XXX	Cable (MMF) Length
001	001=1m
⋮	⋮
050	050=50m
⋮	⋮
100	100=100m

Contact Us



太平貿易株式会社

TAIHEI BOEKI CO., LTD.

光学機器課

〒103-0023 東京都中央区日本橋本町2-2-2

TEL 03-3270-4826 FAX 03-3245-1767

<http://www.taiheiboeki.co.jp>

tokyo@taiheiboeki.co.jp

Copyright © 2021 Broadex Technologies. All rights reserved