

200G QSFP Active Optical Cable

Product Features

- Hot-pluggable QSFP56 form factor
- 200GAUI-4 electrical interface
- CMIS V4.0 compliant
- 4x26.5625GBd PAM4 transmitter and PAM4 receiver
- 4 channels 850nm VCSEL array
- 4 channels PIN photo detector array
- Maximum link length: 70m on OM3 MMF and 100m on OM4 MMF with FEC
- Single +3.3V power supply
- Operation case temperature: 0 to 70°C
- RoHS2 compliant



Applications

- Data Centre, High Performance Computing (HPC)
- Router, Server, Storage, Switch

Absolute Maximum Ratings

Parameter	Unit	Min.	Typical	Max.
Storage Temperature	°C	-45		80
Operating Relative Humidity	%			85
Power Supply not Damaged Voltage	V	-0.3		3.6

Recommended Operating Conditions

Parameter	Unit	Min.	Typical	Max.	Notes
Operating Case Temperature	°C	0		70	
Power Supply Working Voltage	V	3.135	3.3	3.465	
Power Consumption per terminal	W			5	
Bit Rate	Gbps		212.5		
Bit Error Ratio				2.4E-4	1

Note1: PRBS31Q@26.5625GBd. Pre-FEC

Characteristics

All performance is defined over the Recommended Operating Environment unless otherwise specified.

Parameter	Unit	Min.	Typical	Max.	Note
Transmitter					
Signaling Rate per lane (range)	GBd	26.5625 ± 100 ppm			
Differential pk-pk Input Voltage Tolerance	mV	900			
Date Differential Impedance	Ω	90	100	110	
Receiver					
Signaling Rate per lane (range)	GBd	26.5625 ± 100 ppm			
Differential pk-pk Output Voltage Tolerance	mV	-	-	900	
Date Differential Impedance	Ω	90	100	110	

PIN Function Definitions

Pin No.	Symbol	Level / Logic	Description
1	GND		Module Ground
2	Tx2n	CML-I	Transmitter Inverted Data Input
3	Tx2p	CML-I	Transmitter Non-Inverted Data Input
4	GND		Module Ground
5	Tx4n	CML-I	Transmitter Inverted Data Input
6	Tx4p	CML-I	Transmitter Non-Inverted Data Input
7	GND		Module Ground
8	ModSelL	LVTTTL-I	Module Select
9	ResetL	LVTTTL-I	Module Reset
10	VccRx		+3.3V Power Supply for Receiver
11	SCL	LVTTTL-I	2-Wire Serial Interface Clock
12	SDA	LVTTTL-I/O	2-Wire Serial Interface Data Line
13	GND		Module Ground
14	Rx3p	CML-O	Receiver Non-Inverted Data Output
15	Rx3n	CML-O	Receiver Inverted Data Output
16	GND		Module Ground
17	Rx1p	CML-O	Receiver Non-Inverted Data Output
18	Rx1n	CML-O	Receiver Inverted Data Output
19	GND		Module Ground
20	GND		Module Ground
21	Rx2n	CML-O	Receiver Inverted Data Output
22	Rx2p	CML-O	Receiver Non-Inverted Data Output
23	GND		Module Ground
24	Rx4n	CML-O	Receiver Inverted Data Output
25	Rx4p	CML-O	Receiver Non-Inverted Data Output
26	GND		Module Ground
27	ModPrsL	LVTTTL-O	Module Present
28	IntL/RxLOSL	LVTTTL-O	Interrupt. Optionally configurable as RxLOSL via the

			management interface (SFF-8636).
29	VccTx		+3.3V Power Supply for Transmitter
30	Vcc1		+3.3V Power Supply
31	LPMoDe/TxDiS	LVTTL-I	Low Power Mode. Optionally configurable as TxDis via the management interface (SFF-8636).
32	GND		Module Ground
33	Tx3p	CML-I	Transmitter Non-Inverted Data Input
34	Tx3n	CML-I	Transmitter Inverted Data Input
35	GND		Module Ground
36	Tx1p	CML-I	Transmitter Non-Inverted Data Input
37	Tx1n	CML-I	Transmitter Inverted Data Input
38	GND		Module Ground

Electrical Pad Layout

For detail mechanical information, please refer to the related document of SFF-8679.

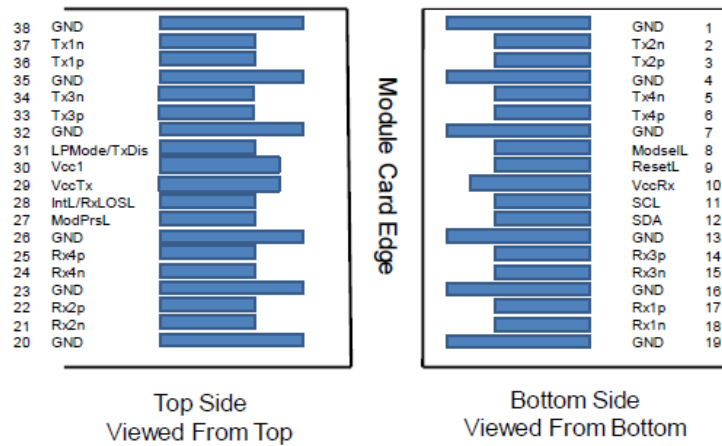
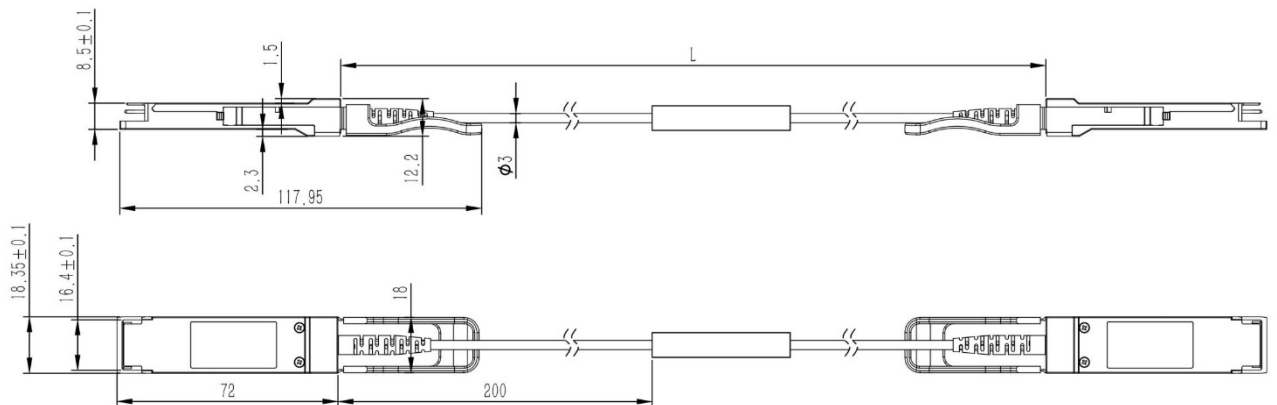

Figure 3: Module contact definition

Mechanical Specifications



Digital Diagnostic Functions

Parameter	Units	Error	NOTES
Temperature Monitor	°C	±3	1LSB=1/256°C
Supply Voltage Monitor	V	±0.1	1LSB=100uV
Bias Current Monitor	mA	±10%	1LSB=2uA
TX Power Monitor	dB	±3	1LSB=0.1uW
RX Power Monitor	dB	±3	1LSB=0.1uW

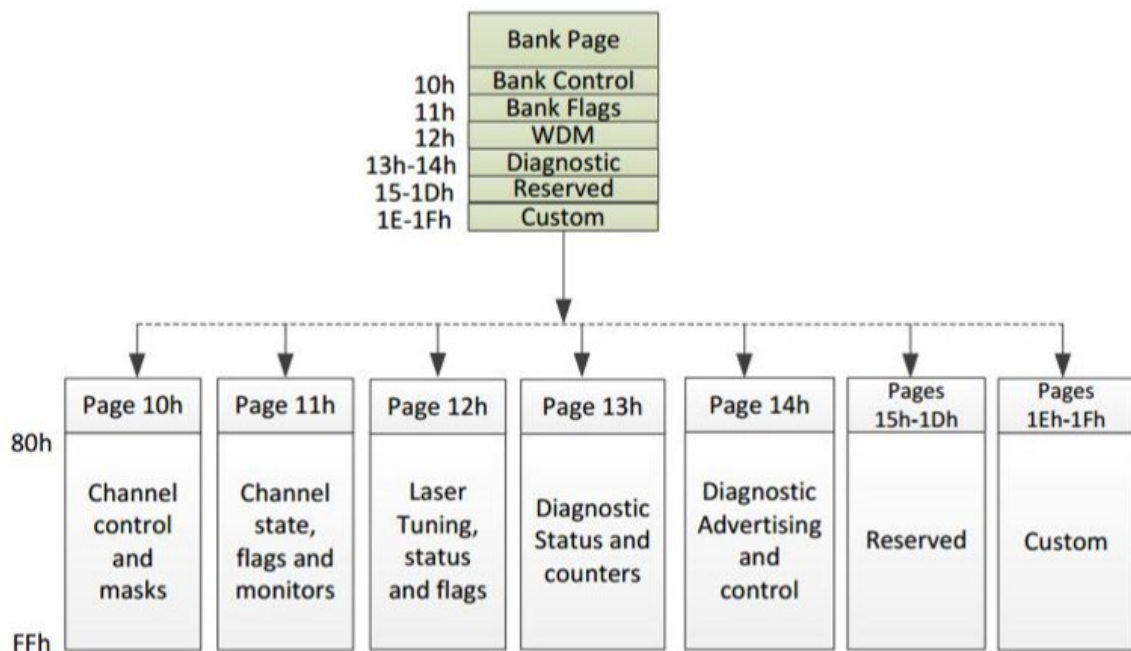

Figure 5. Additional Supported Bank Page Memory Map

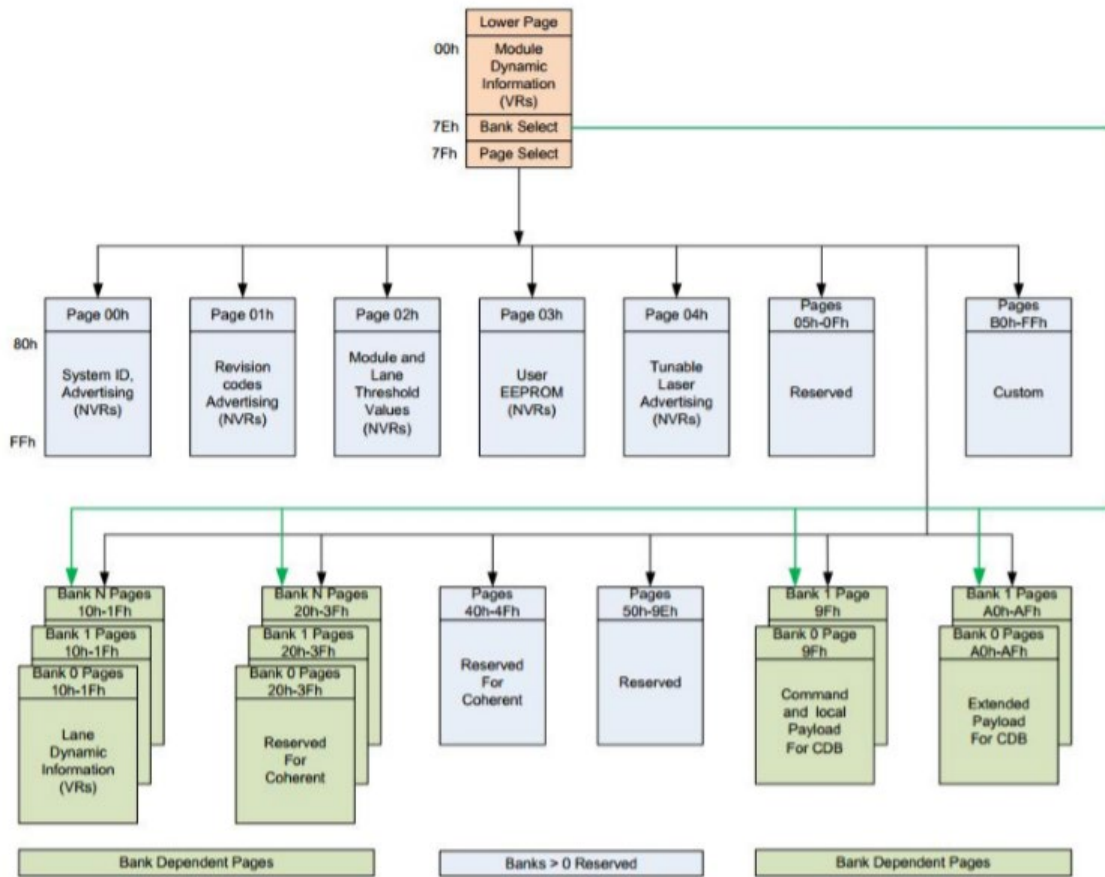

Figure 6. CMIS Bank Page Memory Map

ESD

This product is specified as ESD threshold 1kV for high speed data pins and 2kV for all other electrical input pins, tested per MIL-STD-883, Method 3015.4 /JESD22-A114-A (HBM). However, normal ESD precautions are still required during the handling of this module. This product is shipped in ESD protective packaging. It should be removed from the packaging and handled only in an ESD protected environment.

Ordering Information

Ordering P/Ns	Description
DH88jj-KCCA-xxx	up to 100m, 850nm, 200G QSFP56 to 200G QSFP56 AOC

XXX	Cable Length
005	005=5m
⋮	⋮
050	050=50m
⋮	⋮
100	030=100m

Contact Us

 **太平貿易株式会社**
TAIHEI BOEKI CO., LTD.

光学機器課

〒103-0023 東京都中央区日本橋本町2-2-2

TEL 03-3270-4826 FAX 03-3245-1767

<http://www.taiheiboeki.co.jp>

tokyo@taiheiboeki.co.jp

Copyright © 2020 Broadex Technologies. All rights reserved